



**EnduroFlow<sup>®</sup> Series**  
**EF10 Wall-Mount Ultrasonic Flowmeter**  
**User's Manual**

*UMEF10-12-A*

May, 2012

The following conventions are used through this manual:

**WARNING!**

**Read the declaration carefully before starting any other action!**

**Local safety regulations must be applied!**

**CAUTION!**

**Attention! Damage could occur to the device if handled inappropriately.**

For questions, please call us at +1 978 263 7100 or email us at [support@spiremt.com](mailto:support@spiremt.com).

## Contents

<b>1. Introduction.....</b>	<b>1</b>
§1.1 Preface.....	1
§1.2 Features .....	1
§1.3 Flow Measurement Principle.....	2
§1.4 Packaging List (Standard).....	3
§1.5 Optional Parts.....	3
§1.6 Typical Applications.....	4
§1.7 Product Identification .....	5
§1.8 Specifications .....	5
<b>2. Installation and Measurement.....</b>	<b>7</b>
§2.1 Unpacking .....	7
§2.2 Installation Considerations.....	7
§2.2.1 Mounting the Main Unit.....	7
§2.2.2 Installing Transducers .....	7
§2.2.3 Power Supply Wiring.....	8
§2.2.4 Other Electrical Connections.....	9
§2.3 Power Up .....	9
§2.4 Keypad.....	10
§2.5 Menu Windows.....	11
§2.6 Menu Window List.....	12
§2.7 Steps to Configure the Parameters.....	13
§2.8 Transducer Mounting Allocation.....	15
§2.9 Transducers Wiring .....	16
§2.10 Transducers Installation .....	16
§2.11 Installation Checkup.....	17
§2.11.1 Signal Strength.....	17
§2.11.2 Signal Quality.....	18
§2.11.3 Total Transit Time and Delta Time .....	18
§2.11.4 Transit Time Ratio.....	19
<b>3. How To.....</b>	<b>20</b>
§3.1 How to check if the instrument works properly.....	20
§3.2 How to check the liquid flowing direction.....	20
§3.3 How to change units systems.....	20
§3.4 How to select a flow rate unit.....	20
§3.5 How to use the totalizer multiplier.....	21

§3.6 How to turn on / off the totalizers .....	21
§3.7 How to reset the totalizers .....	21
§3.8 How to restore the factory default setups.....	21
§3.9 How to use the damper to stabilize the flow rate.....	21
§3.10 How to use the low-flow cutoff function.....	21
§3.11 How to conduct Zero calibration .....	22
§3.12 How to change the scale factor.....	22
§3.13 How to use the password locker .....	22
§3.14 How to use the keypad locker .....	23
§3.15 How to use the built-in scheduler.....	23
§3.16 How to use 4-20mA current loop output .....	23
§3.17 How to output analog voltage signal.....	27
§3.18 How to use the Frequency Output.....	27
§3.19 How to use the Totalizer Pulse Output .....	27
§3.20 How to produce an alarm signal.....	28
§3.21 How to use the OCT output.....	29
§3.22 How to use the relay output.....	30
§3.23 How to use the built-in Buzzer.....	30
§3.24 How to modify the built-in calendar .....	30
§3.25 How to adjust the LCD .....	31
§3.26 How to use the RS-485 interface.....	31
§3.27 How to view and reset the yearly/monthly/daily totalizers .....	31
§3.28 How to connect analog input signals.....	31
§3.29 How to compensate the flow not measured during offline .....	32
§3.30 How to use the Working Timer .....	32
§3.31 How to use the manual totalizer .....	32
§3.32 How to use the batch process controller.....	32
§3.33 How to calibrate the 4-20mA current output .....	33
§3.34 How to check the ESN.....	34
§3.35 How to implement leakage detection .....	34
<b>4. Menu Window Details.....</b>	<b>35</b>
<b>5. Troubleshooting.....</b>	<b>42</b>
§5.1 Introduction .....	42
§5.2 Power-on Errors.....	42
§5.3 Working Status Errors .....	43
§5.4 Other Problems and Solutions .....	44
<b>6. Communication Protocol.....</b>	<b>46</b>
§6.1 General.....	46

§6.2 RS-485 Wiring .....	47
§6.3 MODBUS Protocol.....	48
§6.4 Extended Flowmeter Communication Protocol (EFCP) .....	49
§6.4.1 Command prefixes and the command connector .....	51
§6.4.2 Key Value Table .....	52
§6.4.3 Programming Examples .....	53
<b>7. Measurements of Thermal and Other Physical Parameters.....</b>	<b>54</b>
§7.1 Introduction .....	54
§7.2 Wiring Analog Inputs .....	54
§7.3 Thermal Energy Measurement.....	55
§7.4 Configure Analog Measurement Ranges.....	55
§7.5 Read Input Analog Values from a Network Computer.....	56
<b>8. Warranty and Service.....</b>	<b>57</b>
§8.1 Warranty .....	57
§8.2 Service.....	57
§8.3 Software Upgrade Service .....	58
<b>9. Appendix.....</b>	<b>59</b>
§9.1 Wiring Diagram and Outline Drawings .....	59
§9.2.1 Find the mounting site .....	62
§9.2.2 Transducer Configuration Methode .....	62
§9.2.3 Configure the Main Unit.....	63
§9.2.4 Prepare the Pipe Surface .....	63
§9.2.5 Prepare the Transducer .....	64
§9.2.6 Install the Transducers.....	64
§9.2.7 Fine Tune the Installation .....	65
§9.3 Insertion Transducer Installation Guide.....	67
§9.4 Flow-cell Transducer Installation Guide.....	68
§9.5 Standard Pipe Dimensions.....	69
§9.6 Sound Speed Tables .....	70

## 1. Introduction

### §1.1 Preface

The wall-mount EF10 product family is designed to be installed in a fixed location for long-term flow measurement.

The EF10 flowmeter is based on transit-time flow measurement principle. It measures the flow rate of liquid in a closed pipe by using a pair of clamp-on or wetted ultrasonic transducers. In general, the liquid should be full in the pipe, and should contain no or small amount of particles or air bubbles. Examples of applicable liquids are: water (hot water, chilled water, city water, sea water, etc.), sewage, oil (crude oil, lubricating oil, diesel oil, fuel oil, etc.), chemicals (alcohol, acids, etc.), waste water, beverage, liquid food, solvents and other liquids.

The EF10 utilizes state-of-the-art technologies such as advanced signal processing, low-voltage transmitting, small signal detection, self-adaptation, the latest SMD electronics, etc. to achieve high accuracy and reliable performance. Besides, the EF10 provides versatile output interfaces, both analog and digital, which can be easily used by a host computer or a flow controller. The RS-485 communication interface together with MODBUS support and power surge protection makes EF10 the idea device for reliable flowmeter networking.

### §1.2 Features

<ul style="list-style-type: none"> <li>* Repeatability: <math>\pm 0.2\%</math></li> <li>* Accuracy: <math>\pm 1\%</math> of velocity reading <math>\pm 8\text{mm/s}</math></li> <li>* Flow range <math>-32</math> to <math>32\text{ft/s}</math> (<math>-10</math> to <math>10\text{m/s}</math>), bi-directional</li> <li>* Positive / negative / net flow totalizers</li> <li>* Operates with a wide range of Spire Metering transducers, including clamp-on, insertion and flow-cell (spool-piece) transducers</li> <li>* No moving parts, no or minor maintenance</li> <li>* No pressure drop, no disturbance to the flow</li> <li>* Excellent long-term stability</li> <li>* Easy transducer installation</li> <li>* Proprietary low-voltage transmission and self-adaptation technologies</li> <li>* Able to measure electrically conductive and non-conductive liquids</li> </ul>	<ul style="list-style-type: none"> <li>* Isolated RS-485 interface with surge protection, support both MODBUS and proprietary protocols</li> <li>* One isolated 0/4-20mA output</li> <li>* One isolated OCT output and one Relay output programmable to drive alarm, pulse counter, valve</li> <li>* Built-in scheduler for leakage detection</li> <li>* Internal batch process controller</li> <li>* Real-time clock for calendar</li> <li>* 2x20 letters backlight LCD display, 4x4 tactile-feedback membrane keypad</li> <li>* Menu-driving program, easy to use</li> <li>* Optional GPRS/GSM module</li> <li>* Optional RTD interface and BTU measurement</li> <li>* Low-power consumption, <math>&lt; 2\text{W}</math></li> <li>* NEMA 4X (IP65/IP66) weather-resistant enclosure</li> </ul>
--	---

### §1.3 Flow Measurement Principle

The EF10 ultrasonic flowmeter is designed to measure the velocity of liquid within a closed conduit. It uses the well-know transit-time measurement principle plus our proprietary signal processing and ultrasonic transceiving technologies.

As shown in Figure 1.1, the EF10 utilizes a pair of ultrasonic transducers which are mounted on the pipe upstream and downstream respectively. Each transducer functions as both ultrasonic transmitter and receiver. The EF10 main unit operates by alternately transmitting and receiving a coded burst of sound energy between the two transducers. The transit-times in the upstream direction as well as in the downstream direction are measured. The difference of the two transit times is directly and exactly related to the velocity of the liquid in the pipe,

$$V = \frac{MD}{\sin 2\theta} \times \frac{\Delta T}{T_{up} \cdot T_{down}}$$

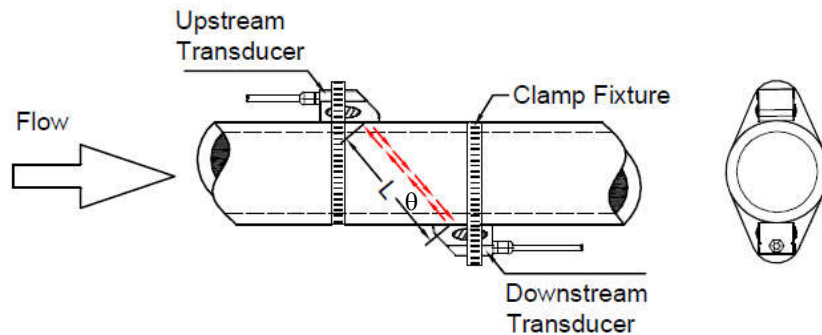

Figure 1.1 Transit-time flow measurement principle

Where:

$\theta$  is the angle between the sound path and the flow direction

M is the number of times the sound traverses the flow

D is the pipe diameter

$T_{up}$  is the time for the beam traveling from upstream the transducer to the downstream transducer

$T_{down}$  is the time for the beam traveling from the downstream transducer to the upstream transducer

$$\Delta T = T_{up} - T_{down}$$

The flow rate is then computed by combining the velocity information with pipe parameters and a scale factor. The scale factor is normally determined by calibration in factory.

Three types of transducers can be used with the EF10 main unit: clamp-on transducer, insertion wetted transducer and flow-cell transducer. All of them do not block the flow, thus, do not generate pressure drop. None of them has moving parts, thus, needs no or very minor maintenance. The transducers can be mounted in V-method where the sound transverses the pipe

fluid twice, or in W-method where the sound transverses the pipe fluid four times, or in Z-method where the transducers are mounted on opposite sides of the pipe and the sound crosses the pipe fluid once. The selection of the mounting methods depends on pipe and liquid characteristics. Please refer to the related Appendix for more details.

### §1.4 Packaging List (Standard)

1. EF10 main unit – standard version	1 unit
2. Transducers	
(1) For clamp-on installation:	
M1-type clamp-on transducer for 2”~28” pipe	1 pair
Clamp-on fixture	1 set
Acoustic couplant	1 unit
(2) For insertion installation:	
Insertion transducer for pipes of 3” and larger	1 pair
Hot-taping tool for metal pipe installation (Optional)	1 set
(3) For inline flow-cell installation:	
Flow-cell transducer	1 piece
3. Transducer cable, 15ft	1 pair
4. User’s Manual	1 unit

### §1.5 Optional Parts

Clamp-on transducers:

Standard temperature, FITTED:

- 1) HF1 - 2MHz, for pipe size ½”
- 2) HF2 - 2MHz, for pipe size ¾”
- 3) HF3 - 2MHz, for pipe size 1”
- 4) HF4 - 2MHz, for pipe size 1 ¼”
- 5) HF5 - 2MHz, for pipe size 1 ½”

Standard temperature, clamp-on, 2MHz:

- 6) HF0 - 2MHz, for pipe sizes ¾”-2”

Standard temperature, clamp-on, 1MHz:

- 7) M1 - 1MHz, for pipe size 2”-28”

Standard temperature, clamp-on, 0.5MHz:

- 8) LF - 0.5MHz, for pipe size 12”-120”

High temperature, clamp-on:

- 9) HF0HT - 2MHz, for pipe size ¾”-2”
- 10) M1HT - 1MHz, for pipe size 2”-28”

Clamp-fixtures



Insertion transducers:

- Insertion transducer for pipe size of 3" or larger
- Hot-tapping tool for insertion transducer installation
- Mounting saddle for non-metal pipes

Flow-cell transducers:

- $\pi$ -type flow-cell transducer for small pipe (3/8"~ 1½")
- Standard flow-cell transducer for large pipe (2"~40")

Dedicated shielded transducer cable

Data logger module

GPRS/GSM module

PT100 temperature sensor, surface-mount type

PT100 temperature sensor, insertion-mount type

PT100 signal conditioning module

Dual-channel analog input module

RS485-USB converter

StufManager<sup>®</sup> PC software

## §1.6 Typical Applications

The EF10 flowmeter can be applied to a wide range of pipe flow measurements. Applicable liquids include pure liquids as well as liquid with small quantity of tiny particles. Examples are:

- Water (hot water, chilled water, city water, sea water, waste water, etc.);
- Sewage with small particle content;
- Oil (crude oil, lubricating oil, diesel oil, fuel oil, etc.);
- Chemicals (glycol, alcohol, acids, etc.);
- Plant effluent;
- Beverage, liquid food;
- Ultra-pure liquids;
- Solvents and other liquids.

Applications sorted by industry / process are:

- Water and waste water management;
- Water and waste water treatment plants;
- Power plants, such as nuclear power plants and hydraulic power plants;
- Mining and metallurgy plants;
- Petroleum process monitoring and control;

Chemical process monitoring and control;  
 Pulp and paper process monitoring and control;  
 Food and beverage processing;  
 Marine maintenance and operation;  
 Pipeline leakage detection;  
 Energy supply and production systems, such as geothermal system, HVAC, BMS, etc.  
 Flow measurement networking.

### §1.7 Product Identification

Each set of the EF10 series flowmeter has a unique product identification number or ESN (electronic serial number) written into the software that can only be modified with a special tool by the manufacturer. In case of any hardware failure, please provide this number which is located on menu window M61 when contacting the manufacturer.

### §1.8 Specifications

Flow Velocity	± 10 m/s (± 32 ft/s). Bi-directional
Accuracy	±1% of reading, plus ±0.008m/s (±0.03ft/s) in velocity*
Repeatability	0.2%
Response Time	0.5s. Configurable between 0.5s and 99s
Display/Keypad	LCD with backlight. 2 x 20 letters. 4 x 4 tactile-feedback membrane keypad. Displays instantaneous flow rate, flow total (positive, negative and net), velocity, time, temperature, energy, analog outputs/inputs
Units	English (U.S.) or metric
Physical Quantity	Volumetric flow rate, total flow, velocity, analog inputs
Totalizers	Positive totalizer, negative totalizer, net totalizer, daily totalizer, monthly totalizer, yearly totalizer, manual totalizer
Security	Keypad can be locked with password
Outputs	
- Current Output	0/4-20mA isolated output for flowrate, velocity or sound speed. Impedance 0-1k. Accuracy 0.1%
- Digital Output	Optically isolated Open Collector Transistor output (OCT). Up to 0.5A load. Can be programmed as: <ul style="list-style-type: none"> <li>- pulse signal for flow totalization</li> <li>- ON/OFF signal for special event such as overflow, no flow, reverse flow, leakage alarming, and more</li> </ul>

EF10 Wall-Mount Ultrasonic Flowmeter

	<ul style="list-style-type: none"> <li>- START/STOP signal for batch control</li> </ul> <p>Can be used to drive pulse counter, external relay, alarm, PLC counter</p>	
- Relay Output	<p>1A@125VAC or 2A@30VDC. Can be programmed as:</p> <ul style="list-style-type: none"> <li>- pulse signal for flow totalization</li> <li>- ON/OFF signal for special event such as overflow, no flow, reverse flow, leakage alarming, and more</li> <li>- START/STOP signal for batch control</li> </ul> <p>Can be used to drive pulse counter, external relay, alarm, PLC counter, or, to control pump, valve, lights</p>	
- Sound Alarm	<p>One sound alarm, programmable to specific event such as overflow, no flow, reverse flow, leakage alarming</p>	
Inputs	<p>One 4-20mA input for temperature, pressure or liquid level transmitter</p> <p>Two temperature channels for accommodating two PT100 4-wire temperature sensors. This function is only available upon request</p>	
Recording	<p>Automatically records the daily total of the last 512 days and the monthly total of the last 128 months</p> <p>Optional SD data logger (2GB space) for recording velocity, flow, status, etc.</p>	
Communication Interface	<p>Isolated RS-485 with power surge protection. Supports the MODBUS protocol</p> <p>Optional RF / GPRS / GSM module for wireless networking, remote monitoring and remote control</p>	
Software	<p>Optional StufManager PC software for real-time data acquisition and remote meter control</p>	
Telemetry**	<p>uGalaxy_GPRS and uGalaxy_GSM wireless telemetry systems are available upon request</p>	
Enclosure	<u>Standard (EF10-x-A)</u>	<u>Enhanced (EF10-x-B)</u>
- Protection	IP65	IP66 (NEMA 4X)
- Dimensions	280mmx190mmx54mm (11"x7.5"x2.1")	305mmx254mmx102mm (12"x10"x4")
- Features	Weather-proof Aluminum, power coded	Weather-proof Polycarbonate. High-impact, UV resistant. UL-50/c-UL Listed
Weight	5kg (10lbs)	7.5kg (15lbs)
Environment Temp	60°C (140°F)	60°C (140°F)
Power sources	12-24 VDC, 90-260 VAC 50/60 Hz  <2W @12VDC	12-24 VDC, 90-260 VAC 50/60 Hz  <2W @12VDC

## 2. Installation and Measurement

### §2.1 Unpacking

Please unpack the shipping box and check the parts and documents against the packing slip. If there is something missing, the device is damaged, or something is abnormal, please contact us immediately and do not proceed with the installation.

#### **WARNING!**

**The EF10 can be used to measure the flow of many kinds of liquids. Some of the liquids may be hazardous. It is very important that you comply with local safety codes and regulations in installing and using electronic devices in your area.**

### §2.2 Installation Considerations

This section provides guidelines for installing the EF10 main unit (electronics box) and its transducers.

#### §2.2.1 Mounting the Main Unit

The EF10 main unit electronics (standard version) are housed in an IP65 (NEMA 4X) weather-resistant and dust-tight enclosure. Therefore, the main unit can be installed indoor and outdoor. Usually, it is mounted in a meter shed or on a location where one can easily access for meter testing and servicing. Please refer to Appendix §9.1 for the enclosure dimensions.

*Note: because the unit is not water-proof, be sure it is not exposed to rain or water when it is installed outdoor.*

#### §2.2.2 Installing Transducers

First, you need to select a proper installation site. For this, one usually needs to consider the accessibility of the location, operating space needed for the installation, safety code compliance, etc. In addition, flow and pipe conditions near the installation site are also very important. Please refer to section §2.8 for site selection details.

Then, follow the installation guidelines given in Appendix §9.2 for installing clamp-on transducers.

If you ordered wetted transducer, either insertion type or flow cell type, please refer to Appendix §9.3 and §9.4 for installation instructions.

#### ***Distance from Main Unit to Transducers***

In general, the closer the transducers to the main unit, the better the signals. Spire Metering can supply up to 1640ft (500m) long transducer cable.

### ***Transducer Cables***

EF10 utilizes a double-balanced driving technique for high performance ultrasonic transmission and receiving. It requires twisted shielded cable for the transducer. We recommend using the cable supplied by the manufacturer. If you want to do the transducer cabling yourself, please consult the manufacturer in advance.

Try not to route the transducer cable along with high current AC lines. Avoid strong interference sources. Make sure the cables and cable connections are protected from weather and corrosive conditions.

**WARNING!**

**The transducers may have static charges accumulated during transportation. Before connecting the transducers to the main unit, please do discharge the transducers in a safe area by shorting the center conductor of the transducer cable connectors to the metal shield of the connector.**

### **§2.2.3 Power Supply Wiring**

Two types of power supply can be used, 90-260VAC and 12-32VDC.

Open the flowmeter enclosure, on the lower right corner (refer to the figures in Appendix §9.1), you should see five terminal blocks which are labeled as DC+, DC-, N, L and E.

If AC power supply is used, connect N, L and E to your power system's Neutral, Line and Earth, respectively. Make sure your Earth ground is good.

If DC power source is used, its positive lead and negative lead should be connected to DC+ and DC-, respectively.

Please refer to Appendix §9.1 for more wiring information.

**WARNING!**

**Be careful about the power supply type of your flowmeter and the power supply wiring! Connecting to a wrong type power source or improper connection of line power could damage the flowmeter. It may also cause hazardous voltage at enclosure, the transducer, flow cell, and associated piping.**

### **Backup Battery**

There is a 3V coin cell battery, CR2032, on the main board which is used to backup the calendar real-time clock (RTC). When the main power is off, this battery will keep RTC running. Its lifetime is normally about 3 years. Replace the battery with the same type when necessary. Please disconnect the main power and wear an anti-static wrist strap to prevent electro-static damage to the main board electronics.

If time stamping is not needed for data recording, you may remove this battery from the board.

**WARNING!**

**There might be risk of explosion if the battery is replaced with an incorrect type. Batteries should be recycled where possible. Disposal of used batteries must comply with local environmental regulations.**

## §2.2.4 Other Electrical Connections

### *Wiring RS-485*

Refer to sections §6.2 and Appendix §9.1 for details.

### *Wiring 0/4-20mA Output*

Using standard twisted-pair wiring. Refer to §3.16 for details.

### *Wiring 0/4-20mA Input*

The analog input channel can be wired to terminal block pins AI3 and AGND using standard twisted-pair wiring. Please refer to section §3.28 and Chapter 7 for more information.

### *Wiring Alarms*

You may use the OCT output or the relay output to drive alarms. The maximum electrical ratings for the OCT and relay are listed in the §1.8 *Specifications*. Using standard twisted-pair wiring. Refer to sections §3.21 and §3.22 for details.

## §2.3 Power Up

The EF10 does not have power ON/OFF switch. When it is connected to power, it will start to run automatically.

After the power is turned on, the flowmeter will run a self-diagnostic program, checking first the hardware and then the software integrity. If there is any abnormality, corresponding error messages will be displayed. (Please refer to chapter 5 for error code explanations.)

**WARNING!**

**Before connecting the device to power source, please do a final check to make sure all the wirings are correct and all the local safety codes are followed.**

After successful internal checks, the EF10 will display menu window #01 (short for M01), or the menu window which was active at last power off. It will also start the measurements by using the parameters configured and saved last time by the user or by the initial program.

The flow measurement program always operates in the background of the user interface. This means that the flow measurement will keep running regardless of any user menu window browsing or viewing. Only when the user enters new pipe parameters will the flowmeter change measurement to reflect the new parameter changes.

When the power is turned on or new pipe parameters are entered, the flowmeter will enter into a self-adjusting mode to adjust the gain of the receiving circuits so that the signal strength will be within a proper range. By this step, the flowmeter finds the best system gain which matches the pipe material and fluid type. The user will see the progress by the number s1, s2, s3 and s4, located on the upper left corner of the LCD display. If the self-adapting process is completed successfully, letter “#R” will be displayed.

When the user adjusts the position of the installed transducers, the flowmeter will re-adjust the signal gain automatically.

Any user-entered configuration value can be stored in the NVRAM (non-volatile memory) by using M26, until it is modified by the user.

**§2.4 Keypad**

The keypad of the flowmeter has 16 keys (Figure 2.1).

Keys  ~  and  are keys to enter numbers.

Key  is the going UP key when the user wants to go to the upper menu window. It also works as + key when entering numbers.

Key  is the going DOWN key when the user wants to go to the lower menu window. It also works as the – key when entering numbers.

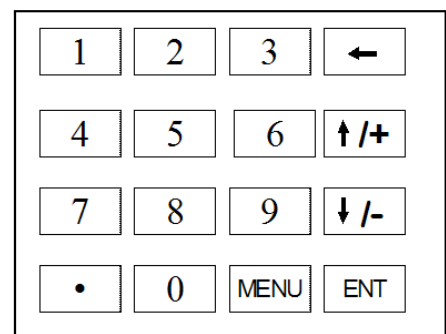





Figure 2.1 Keypad layout

Key  is the backspace key when the user wants to go left or wants to backspace the left character that is located to the left of the cursor.

Key  is the ENTER key for any input or selections.

Key  is the key for the direct menu window jump over. Whenever the user wants to proceed to a certain menu window, the user can press this key followed by a 2-digit number.





The  key is shortened as the ‘M’ key hereafter when referring to menu windows.





Key-pressing induced beep sound can be enabled / disabled in menu window M77.



## §2.5 Menu Windows

The EF10 user interface comprises about 100 independent menu windows that are numbered by M00, M01, M02, ..., M99, M+0, M+1, etc.

There are two methods to visit a menu window:









(1) Direct jump in. Simply press the  key followed by a 2-digit number. For example, if you want to visit menu window M11 for pipe outer diameter, press the following three keys consecutively,   .

(2) Press the  or  key. Each time of the  key pressing will lead to the lower-numbered menu window. For example, if the current window is on M12, the display will go to window M11 after the  key is pressed once.

You do not need to remember all the menu windows. Just remember the most commonly used window numbers and the approximate window number of some uncommonly used windows would be sufficient. You can always use  or  key to find the right window.

There are three different types of menu windows:

- (1) Menu windows for number entering, e.g., M11 for setting up pipe outer diameter.
- (2) Menu windows for option selection, e.g., M14 for the selection of pipe materials.
- (3) Results display windows, e.g., window M00 for displaying flow rate, etc.

For number entering windows, the user can directly press the digit keys if the user wants to modify the value. For example, if the current window is on M11, and the user wants to enter 219.2345 as the pipe outer diameter, then, the flowing keys should be pressed:         .

For option selection windows, the user should first press the  key to get into option selection



mode. Then, use  $\uparrow/+$ ,  $\downarrow/-$ , or digit key to select the right option. Consequently, press the  $\text{ENT}$  to make the selection.

For example, assume your pipe material is stainless steel and you are currently on menu window M14 which is for the selection of pipe materials (if you are on a different window, you need to press  $\text{MENU}$   $\boxed{1}$   $\boxed{4}$  first in order to enter into the M14 window.) You need to press the  $\text{ENT}$  key to get into the option selection mode. Then, either press the  $\uparrow/+$  or  $\downarrow/-$  key to make the cursor on the line that displays “1. Stainless Steel”, or press the  $\boxed{1}$  key directly. At the end, press  $\text{ENT}$  again to make the selection.

Generally, the  $\text{ENT}$  key must be pressed to get into the option selection mode for option modifications. If the “Locked M47 Open” message is indicated on the bottom line of the LCD display, it means that the modification operation is locked out. In such cases, the user should go to M48 to have the instrument unlocked before any further modification can be made.

## §2.6 Menu Window List

M00~M09 windows for the display of the instantaneous flow rate, net totalizer value, positive totalizer value, negative totalizer value, instantaneous flow velocity, date time, current analog input values, current working status, etc.

M10~M29 windows for entering system parameters, such as pipe outer diameter, pipe wall thickness, liquid type, transducer type, transducer installation method, etc. Transducer installation spacing is then calculated according to those parameters and displayed on one of the windows.

M30~M38 windows for flow rate unit selection and totalizer configuration. User can use these windows to select flow rate unit, such as cubic meter or liter, as well as to turn on / off each totalizer, or to reset the totalizers.

M40~M49 windows for setting response time, zeroing / calibrating the system, locking / unlocking keypad, changing network address ID, password, etc.

M50~M89 windows for digital and analog outputs, such as scheduled output, RS-485 output, relay output, analog current loop output, LCD, frequency output, alarm output, analog inputs. Besides, there are also windows for configuring analog inputs, date / time, and day/month/year accumulator.

M90~M94 windows for displaying diagnostic data, including the installation triplet. Those data are very useful when doing a more accurate measurement.

M95 Upon entering into this window, the circular display function is started automatically. The following windows will be displayed one by one, each window will stay for about 4 seconds: M95 -> M00 -> M01 -> M02 -> M03 -> M04 -> M05 -> M06 -> M07 ->

M08 -> M09 -> M90 -> M95.

M+0~M+9 windows for some additional functions, including a single precision calculator, display of the total working time, and display of the time and the flow rate when the device is turned on and turned off.

Other menu windows are used for factory debugging.

For detailed explanation of the above windows please refer to chapter 3 “How to” and chapter 4 “Menu Window Details”.

### **§2.7 Steps to Configure the Parameters**

In order to make the EF10 work properly, one must program the flowmeter with application information and installation information properly, so that the flowmeter is able to lock to the right signal. The flowmeter will also automatically calculate the transducer spacing which is useful for you to install the transducers.

If you are using flow-cell transducer, however, most of the parameters may have already been programmed in the factory. You may only need to verify the fluid information (M20-M21), make sure the liquid type in M20 is what is in your pipe. Note that the pipe information (M11-M19) should be those of the flow-cell, not that of your pipe.

If you are using clamp-on or insertion type transducer, please follow these steps to configure the system:

#### **(1) Pipe size and pipe wall thickness**

For standard pipe, please refer to Appendix §9.4 for outer diameter and wall thickness data. For non-standard pipe, the user has to measure these two parameters.

Enter OD and wall thickness in M11 and M12. The flowmeter will calculate the ID and put it into M13.

#### **(2) Pipe materials**

For standard pipe material, select the proper type from the list in M14. The sound speed value of that material, which was pre-stored in the memory, will be used automatically.

For non-standard pipe material, the sound speed of the material must be entered. Please refer to Appendix §9.5 for sound speed data.

#### **(3) Liner material, its sound speed and liner thickness**

If liner exists, enter the liner parameters in M16-M18.

#### **(4) Liquid type**

For standard liquid material, select the proper type from the list in M20. The sound speed and viscosity values of that material, which were pre-stored in the memory, will be used automatically.

For non-standard liquid material, the sound speed and viscosity of the material must be entered. Please refer to Appendix §9.5 for sound speed and viscosity data.

(5) Transducer type

Transducer type selection is in M23.

For S1/M1/L1 type, select Standard S1/ Standard /M1/ Standard L1.

For insertion type, select Insertion B

For flow-cell transducer, select Pi-Transducer for Pi-type and Insertion B for standard type.

(6) Transducer mounting method

V-method and Z-method are the common methods. Make selection in M24.

Refer to Appendix §9.2 on which method to use.

(7) Transducer spacing

Write down the transducer spacing in M25. You will use it later when install the transducers.

(8) Save configuration

Example: For standard (commonly used) pipe materials and standard (commonly measured) liquids, the parameter configuration steps are as following:

- (1) Press keys **MENU** **1** **1** to enter into M11 window. Input the pipe outer diameter through the keypad and press **ENT** key.
- (2) Press key **↓/-** to enter into M12 window. Input the pipe thickness through the keypad and press **ENT** key.
- (3) Press key **↓/-** to enter into M14 window. Press **ENT** key to get into the option selection mode. Use keys **↑/+** and **↓/-** to scroll up and down to the proper pipe material, and then press **ENT** key.
- (4) Press key **↓/-** to enter into M16 window. Press **ENT** key to get into the option selection mode. Use keys **↑/+** and **↓/-** to scroll up and down to the proper liner material, and then press **ENT** key. Select “No Liner”, if there is no liner.
- (5) Press key **↓/-** to enter into M20 window. Press **ENT** key to get into the option selection mode. Use keys **↑/+** and **↓/-** to scroll up and down to the proper liquid, and then press **ENT** key.
- (6) Press key **↓/-** to enter into M23 window. Press **ENT** key to get into the option selection mode. Use keys **↑/+** and **↓/-** to scroll up and down to the proper transducer type, and then press **ENT** key.
- (7) Press key **↓/-** to enter into M24 window. Press **ENT** key to get into the option selection mode. Use keys **↑/+** and **↓/-** to scroll up and down to the proper transducer mounting method, and then press **ENT** key.
- (8) Press key **↓/-** to enter into M25 window. The transducer installation distance will be displayed on the window. Based on this distance and the transducer installation method selected above, install the transducers on the pipe (refer to Appendix §9.2 for more installation details.)
- (9) After installation is completed, check if the triplet (signal strength S, signal quality Q and transit-time ratio R) are in the right range. Press keys **MENU** **9** **0** to enter into M90

window to read the value for S and Q and press **MENU** **9** **1** to read the value for R.

(10) Press **MENU** **2** **6** to enter into window M26, press **ENT** **1** **ENT** to save the above configuration results into non-volatile memory.

(11) Press **MENU** **0** **1** to enter into window M01 to read the measurement result.

### §2.8 Transducer Mounting Allocation

The first step in the installation process is to select an optimal location for installing the transducers in order to make the measurement reliable and accurate. Prior to installation, having a basic knowledge about the piping and its plumbing system is recommended.

An optimal location would be defined as a long straight pipe line full of liquid that is to be measured. The piping can be in vertical or horizontal position. The following shows examples of optimal locations.

Principles to select an optimal location:

- (1) Pipe must be full of liquids at the measurement site.
- (2) No heavy corrosion or deposition inside of the pipe.
- (3) Must be a safe location.

(4) The straight pipe should be long enough to eliminate irregular-flow-induced error. Typically, the length of the straight pipe should be 15 times of the pipe diameter, the longer the better. The transducers should be installed at a pipe section where the length of the straight pipe at upstream side is at least 10D and at downstream side is at least 5D, where D stands for pipe outer diameter.



Piping Configuration and Transducer Position	Upstream Dimension	Downstream Dimension
	L up x Diameters	L dn x Diameters
	10D	5D
	10D	5D
	10D	5D
	12D	5D
	20D	5D
	20D	5D
	30D	5D

Figure 2.2 Installation site selection.

- (5) If there are flow disturbing parts such as pumps, valves, etc. on the upstream, the straight pipe length should be increased (refer to the table on the right for more details.) The disturbance strength are in the following order (low to high): *Single Bend*

-> *Pipe Reduction / Enlargement* -> *Outflow Tee* -> *Same Plane Multiple Bends* -> *Inflow Tee*  
-> *Out of Plane Multiple Bends* -> *Valve* -> *Pump*.

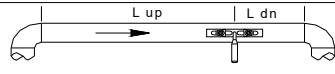
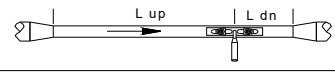
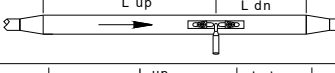
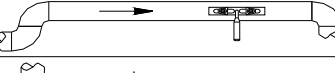
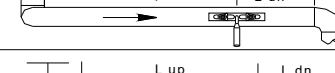
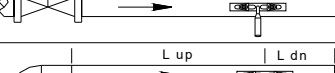
- (6) Make sure that the temperature on the location does not exceed the range for the transducers. Generally speaking, the closer to the room temperature, the better.
- (7) Select a relatively new straight pipe line if it is possible. Old pipe tends to have corrossions and depositions, which could affect the results. If you have to work on an old pipe, we recommend you to treat the corrossions and depositions as if they are part of the pipe wall or as part of the liner. For example, you can add an extra value to the pipe wall thickness parameter or the liner thickness parameter to take into account the deposition.
- (8) Some pipes may have a kind of plastic liner which creates a certain amount of gaps between liner and the inner pipe wall. These gaps could prevent ultrasonic waves from direct traveling. Such conditions will make the measurement very difficult. Whenever possible, try to avoid this kind of pipe. If you have to work on this kind of pipe, we recommend you to use our insertion type transducers that are installed permanently on the pipe by drilling holes on the pipe wall. Refer to Appendix §9.3 for details.
- (9) When select the measurement site, you may need to consider where to mount the flowmeter main unit. Normally, the EF10 electronics are housed in a weather-resistant enclosure. It can be mounted in a meter shed, or a location that allows easy access to the flowmeter for programming and servicing.
- (10) When select the measurement site, you may also need to consider how to install the transducers. Make sure you have enough space for easy operation.

## **§2.9 Transducers Wiring**

Since the EF10 utilizes balanced topology for high-performance ultrasonic transmitting and receiving, it is recommended to use high-frequency twisted cable with shielding as the transducer cable in order to guarantee the signal quality. Please refer to section §2.2 and Appendix §9.1 on how to wire transducers to the flowmeter terminals.

## **§2.10 Transducers Installation**

The transducers used by the EF10 series ultrasonic flowmeter are made of piezoelectric crystals both for transmitting and receiving ultrasonic signals through the wall of liquid piping system. The measurement is realized by measuring the traveling time difference of the ultrasonic signals. Since the difference is very small, the spacing and the alignment of the transducers are critical factors to the accuracy of the measurement and the performance of the system. Meticulous care should be taken for the installation of the transducers.

Clamp-on transducer installation steps:

- (1) Locate an optimal position where the straight pipe length is sufficient (see the previous section), and where pipes are in a favorable condition, e.g., newer pipes with no rust and ease of operation.
- (2) Calculate the transducer spacing. Just enter the pipe, fluid and transducer information through menu M11 to M24, the flowmeter will calculate the transducer spacing automatically. The value will be shown in M25. Marking the transducer installation spots on the pipe according to this spacing value.
- (3) Clean any dust and rust on the spot where the transducers are to be installed. For a better result, polishing the pipe outer surface with a sander is strongly recommended.
- (4) Apply adequate ultrasonic couplant (grease, gel or Vaseline) onto the transducer surface as well as to the installation area on the pipe surface.
- (5) Strap on the transducers using clamp fixture. The transducer has magnetic built-in, thus, it may be able to attach itself to the pipe if the pipe is metal. However, we still recommend to use clamp fixture to fasten the transducer on to the pipe. Make sure there is no gap between the transducer surface and the pipe surface.
- (6) Fine tune transducer position until the triplet, signal strength S, signal quality Q and transit-time ratio R, have the best readings and those reading are in their *operational ranges* ( $S \geq 60$ ,  $Q \geq 60$  and  $97\% \leq R \leq 103\%$ ). It is even better if you can tune those readings into their *optimal ranges* ( $S \geq 80$ ,  $Q \geq 80$  and  $99\% \leq R \leq 101\%$ ). Note, for large velocity flow, the R values may exceed this range to some degree.

You may also need to check the measured liquid sound speed (M92) to see if it is close to the theoretic one of the liquid (you may find this info from a physical handbook if you know the liquid material).

For more details on clamp-on transducer installation, please refer to Appendix §9.2.

For wetted transducer installation, please refer to Appendix §9.3.

## §2.11 Installation Checkup

After the completion of transducer installation, the user should check the following three parameters (the **triplets**): signal strength S, signal quality Q and transit-time ratio R. The triplet values should fall into their range. One may also need to check delta time (traveling time difference between the upstream and the downstream signals), estimated liquid sound speed, and etc. As such, one can be sure that the flowmeter is working properly and the results are reliable and accurate.

### §2.11.1 Signal Strength

Signal strength S indicates the amplitude of receiving ultrasonic signals by a 3-digit number. [00.0] means there is no signal detected, and [99.9] refers to the maximum signal strength that can be

received. Note that sometimes when no confusion will be introduced, S value is expressed by two digits (00-99) for simplicity.

Although the instrument works well when the signal strength ranges from 60 to 99, stronger signal strength should be pursued, because a stronger signal means a better result. The following methods are recommended to obtain strong signals:

- (1) If the current location is not good enough for a stable and reliable flow reading, or if the signal strength is lower than 60, relocate to a more favorable location.
- (2) Try to polish the outer surface of the pipe, and apply more couplant to increase the signal strength.
- (3) Tenderly adjust the position of the two transducers, both vertically and horizontally, while checking the signal strength. Stop at the position where the signal strength reaches to maximum. Then, check the transducer spacing to make sure it is the same as or very close to what window M25 shows.
- (4) If the installation method is V-method and the pipe is big, you may need to try Z-method in order to get stronger signals.

### **§2.11.2 Signal Quality**

Signal quality is indicated as the Q value in the instrument. A higher Q value would mean a higher Signal to Noise Ratio (SNR), and accordingly a higher degree of accuracy able to be achieved. Under normal pipe condition, the Q value is in the range of 60-99, the higher the better.

Causes for a lower Q value could be:

- (1) Interference from other instruments and devices nearby, such as a power frequency transverter which could cause strong interference. Try to relocate the flowmeter to a new place where the interference can be reduced.
- (2) Bad sonic coupling between the transducers and the pipe. Try to polish the pipe surface again, clean the surface and apply more couplant, etc.
- (3) The selected pipe section is difficult to conduct the measurement. Relocate to a more favorable pipe line.

### **§2.11.3 Total Transit Time and Delta Time**

The total transit time (or traveling time) and the delta time are displayed on menu window M93. They are the primary data for the instrument to calculate the flow rate. Therefore, the measured flow rate will vary as the total transit time and delta time vary.

The total transit time should remain stable or vary in a very small range.

The delta time normally varies less than 20%. If the variation exceeds 20% in either positive or negative direction, there could be certain kinds of problems with the transducer installation. The user should check the installation for sure.

#### §2.11.4 Transit Time Ratio

Transit-time ratio R is usually used to check whether the transducer installation is good and whether the entered pipe parameters are in consistency with their actual values. If the pipe parameters are correct and the transducers are installed properly, the transit time ratio should be in the range of  $100\pm 3\%$ . Particularly, when the flow is stand-still, the ratio should be very close to 100%. If this range is exceeded, the user should check:

- a) If the entered pipe parameters are correct?
- b) If the actual spacing of the transducers is the same as or close to what shown on window M25?
- c) If the transducer are installed properly in the right direction?
- d) If the mounting location is good, if the pipe has changed shape, or if the pipe is too old (i.e., too much corrosion or deposition inside the pipe)?
- e) If there is any interference source inside the pipe?
- f) If there are other aspects which do not meet the measurement requirements as recommended earlier?

For more tips, please visit our technical support site: <http://www.spiremt.com/support/>



## 3. How To

### §3.1 How to check if the instrument works properly

Switch to menu M08 by entering    keys. If 'R' is displayed on the screen, the instrument is working properly.

If 'E' is displayed, the current loop output is over-ranged. Increasing the range setting in M57 will make the 'E' letter disappear. If you do not use current loop output, you may ignore this error.

If 'Q' is displayed, the frequency output is over-ranged. Increasing the range setting in M69 will make the 'Q' letter disappear. If you do not use frequency output, you may ignore this error.

If 'G' is displayed, the flowmeter is adjusting system gain. This is normal as long as it does not last long.

If 'I' is displayed, there is no signal received. Check if the transducer cables are connected properly and transducers are clamped firmly.

If 'J' is displayed, there is hardware problem. Turn off the power, then, turn on the power again. If the problem remains, refer to Chapter 5 for diagnosis details.

If an 'H' flashes instead, the received signal is poor.

Please refer to Chapter 5 for diagnosis information.

### §3.2 How to check the liquid flowing direction

Assume that transducer A is connected to the upstream terminals and transducer B is connected to the downstream terminals.

First, make sure that the instrument works properly.

Then, check the flow rate reading. If the value is positive, the direction of the flow will be from transducer A to B. Otherwise, the flow is from B to A.

### §3.3 How to change units systems

Use menu window M30 for the selection of units systems, either English (option 0) or in Metric (option 1).

### §3.4 How to select a flow rate unit

Use menu window M31 to select the flow rate unit, use menu window M32 to select the flow totalizer unit.

### **§3.5 How to use the totalizer multiplier**

Use window M33 to select a proper multiplying factor for the totalizers (POS, NEG and NET). Make sure that the rate of the totalizer pulse is not too fast, neither too slow. A speed of several pulses per minute is preferable.

If the totalizer multiplying factor is too small, the output pulse will be very fast and there could be a loss of pulses. The designed minimum pulse period is 500 milliseconds.

If the totalizer multiplying factor is too large, the output pulse will be very slow, which might be a problem if the master device requires fast response.

### **§3.6 How to turn on / off the totalizers**

Use M34, M35 or M36 to turn on or turn off the POS, NEG or NET totalizer, respectively.

### **§3.7 How to reset the totalizers**

Use M37 to reset the flow rate totalizers.

### **§3.8 How to restore the factory default setups**

Go to window M37. Press the   Keys. This operation will erase all the parameters entered by the user and setup the instrument with factory default values.

### **§3.9 How to use the damper to stabilize the flow rate**

The damper acts as a filter for a stable reading. Its damping constant is entered in window M40. Its unit is in second. If '0' is entered, that means there is no damping. A bigger constant number brings a more stable effect. But bigger numbers will prevent the instrument from acting quickly.

A constant from 5 to 30 is commonly used for the damper value.

### **§3.10 How to use the low-flow cutoff function**

The value displayed in window M41 is the low-flow cutoff. When the absolute value of the measured flow velocity is below this value, the measured velocity as well as flow rate will be replaced with '0'. This is to avoid any invalid accumulation when the actual flow is below the low-flow cutoff value.

Application example: when a pump is shut down, the liquid will not stop immediately. It will keep moving (may be backward) for a little while. During this period, the totalizer should be prevented from accumulating. This can easily be done by setting the low-flow cutoff velocity to a certain

value, such as 0.1ft/s (0.03m/s)

The low-flow cutoff operation does not affect the flow measurement when the actual flow is greater than the low-flow cutoff value.

### §3.11 How to conduct Zero calibration

When the flow in a pipe is absolutely stopped, the flowmeter could still give a small non-zero flow rate reading due to transducer installation or pipe-sensor mismatching. In order to make the measurement accurate, it is necessary to remove this “Zero Point” reading.

Window M42 allows us to take care of this issue. At first, the user should make sure that the liquid in the pipe is totally stopped (no velocity). Then, go to window M42 and press the **ENT** key to start the zero calibration (or zero point setup) function. Wait until the counter reading goes down to ‘00’.

You must then save the Zero Point into the flowmeter non-volatile FLASH memory so that it will not get lost when power is off. This can be done by simply pressing keys **MENU** **.** **2**.

### §3.12 How to change the scale factor

You may change the scale factor in menu window M45. After the change, we recommend you to save the value to the non-volatile FLASH memory. Press keys **MENU** **2** **6** to enter into window M26, then, press **ENT** **1** **ENT** to save.

A scale factor is the ratio between the ‘actual flow rate’ and the flow rate measured by the flowmeter. It can be determined by calibration with a standard flow calibration equipment. Please go to our technical support site <http://www.spiremt.com/support/> to see the instructions.

The scale factor is transducer dependent. Prior to shipment from the factory, the scale factor of a transducer pair is calibrated on a pipe with water flow. If you ordered multiple pairs of transducers, be sure you enter the scale factor of the transducer pair you are using. Also, we recommend you to do a Zero calibration (refer to the above section) each time after the transducer change.

The scale factor is also affected by other factors such as pipe size, fluid viscosity, installation variation, etc. It is therefore recommended to do on-site calibration when accuracy is of crucial importance.

### §3.13 How to use the password locker

The password locker provides a means of preventing inadvertent configuration changes or totalizer resets. When the system is locked, the user can still browse menu windows, but cannot make any modifications on the windows.

The password locking / unlocking is done in window M47. The system can be locked without a password or with a password consisted of 1 to 4 digits.

For no-password locking / unlocking, just press **ENT** key in window M47.

If the password is forgotten, please contact the manufacturer.

### §3.14 How to use the keypad locker

First, switch to the menu window which will be displayed after the keypad is locked.

Then, press **MENU** **4** **8** to switch to menu M48. Press **ENT** and enter a 1-8 digit long password. Password should be numerical only. Press **ENT** again to set the password. The system will return to the previously selected window automatically.

To unlock keypad, press **ENT**, enter the password, and press **ENT** again.

### §3.15 How to use the built-in scheduler

EF10 has a built-in scheduler which allows user to set a specific period of time to conduct one of the following activities:

- Send data to the internal serial port
- Start to monitor the flowrate, and trigger an alarm if it is over a preset threshold
- Start to accumulate flow, and trigger an alarm if the flow total is over a preset threshold

The first activity is reserved for 4-20mA output, printer and other future extended functions. Data items to be sent to the internal serial port are selected in M50.

The last two activities can be used for leakage detection and scheduled dosing or batching.

The scheduler parameters are set in M51. They include the starting time, time interval and number of times to repeat the activity.

For example, if you want to start the activity at 9.30pm, stop at 11.00pm, and repeat this 50 times, you need to enter the following parameters in M51:

Start Time	21:30:00
Interval	01:30:00
Last	50

The scheduler can be used for leakage detection and timed batch delivery. Please refer to sections §3.32 and §3.35 for more details.

### §3.16 How to use 4-20mA current loop output

EF10 has one channel of isolated 4-20mA analog output. The accuracy of this output is better than 0.1%. It can be configured to different mode, such as 4-20mA mode, 0-20mA mode, etc. Mode selection can be made in menu M55. Refer to the next chapter for details on M55.

In order to use the 4-20mA output function, you need to not only select the mode to be 4-20mA in M55, but also set the flow rate values which correspond to the minimum current (4mA) and the maximum current (20mA). Enter the two values in M56 and M57.

Example A: flow rate range is 0-500m<sup>3</sup>/h. Just enter 0 in M56 and 500 in M57.

Example B: flow rate range is -500-0-1000m<sup>3</sup>/h. If flow direction is not an issue for you, you may select 20-4-20mA mode in M55. Then, enter 500 in M56 and 1000 in M57. If flow direction is an issue, you may select 0-4-20mA mode in M55. This means that the current loop will output 0-4mA when flow rate is negative and 4-20mA when flow rate is positive. Enter -500 in M56 and 1000 in M57.

You may need to calibrate and test the current loop output before using it. Just go to menu M58 and do the following:

First, connect an ammeter to the current loop output.

Press **MENU** **5** **8**, then, **ENT** to enter into menu M58.

Use **↑/+** and **↓/-** to display “0mA”, “4mA”, “8mA”, “16mA”, “20mA” orderly, record the corresponding reading on the ammeter. Calculate the differences between the readings and the selected ones. For instance, when 4mA is selected, the actual output current shown on the ammeter is 4.01mA. Then, the difference is 0.01mA.

If the differences are not within tolerance, calibrate the current loop (see section §3.33.)

The present current loop output is displayed in Window M59. It changes along with flow rate change.

#### *Wiring:*

The device which you will connect to EF10 transmitter could be a DCS, PLC or other data acquisition device. We will call them **Load**, marked as RL in figure 3.1.

There are two ways to wire this analog output to an external load: loop-powered method and non-loop powered method.

First, you need to check your load to see whether it is a “source” or a “sink”. A source will provide DC power to the 4-20mA interface. A sink draws current, thus, will need an external power supply for the 4-20mA interface.

If you do not know whether your load is a source or sink, you may use a resistor with value of 1-10kOhm to connect across the two input wires from your load, and use a multimeter to measure the voltage across the resistor. If you get more than 0.2VDC, it will be a source. Otherwise, it is a sink.

If your load is a source type, check what voltage it provides for the 4-20mA interface. If the voltage is between 12VDC and 20VDC, you may use the loop-powered method (Figure 3.1a) to wire your load to the 4-20mA output. Otherwise, please contact [support@spiremt.com](mailto:support@spiremt.com).

If your load is a sink type, you may use non loop-powered method (Figure 3.1b or Figure 3.1c).

(1) Loop-powered method

If your load is a source type, which means it has a DC power for the 4-20mA interface already, you do not need to provide external power anymore.

The flowmeter 4-20mA output circuit functions as a sink in this case. It draws power from the loop. The minimum sink current is about 3mA.

This wiring method ensures that the 4-20mA output is isolated from the flowmeter electronics.

Please note that the flow transmitter EF10 could be powered by either a DC power (12VDC ~ 24VDC) supply or an AC power supply (90VAC ~ 240VAC).

4~20mA loop Powered

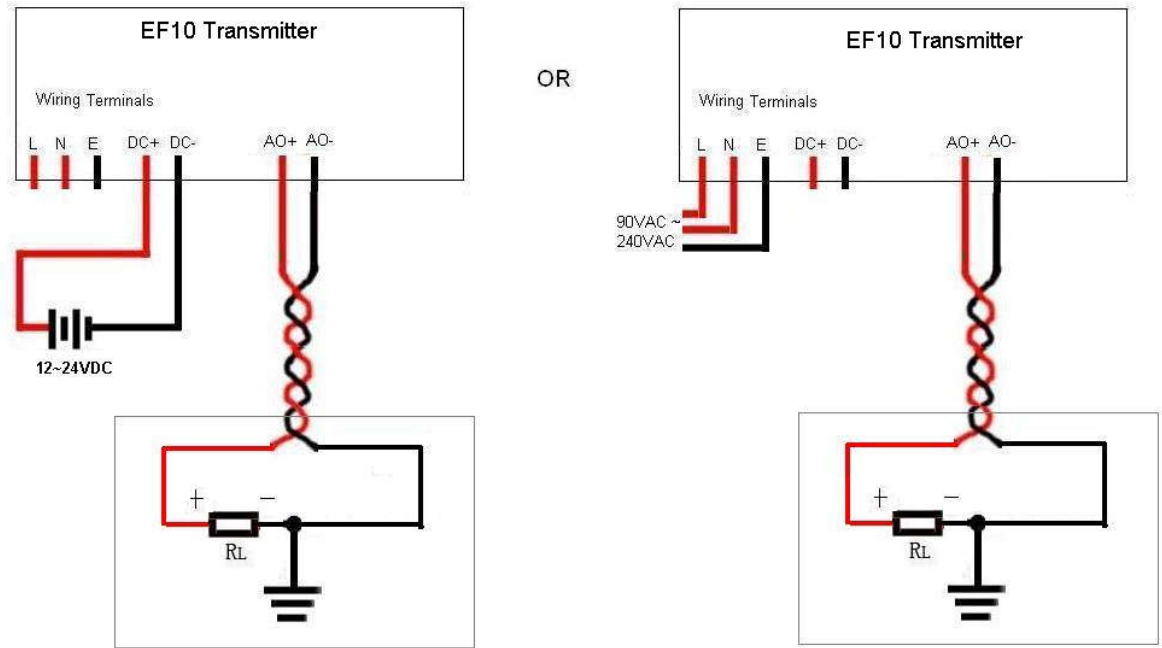

Figure 3.1a. 4-20mA wiring diagram - loop-powered method

(2) Non loop-powered method

If your load is a sink type, an extra power supply is needed. In this case, you may use the internal power supply of the EF10 transmitter (Figure 3.1b), or, use an external power supply (Figure 3.1c).

If you use the flow transmitter internal power supply, the flow transmitter will function as a source, and your load functions as a sink. Since the 4-20mA ground of the transmitter is connected to the flow transmitter's power ground, the 4-20mA output is not isolated output

anymore. As showing in Figure 3.1b, the two output terminals in the flow transmitter are AO- and DC-. The AO+ terminal is not used.

4~20mA Non-loop Powered

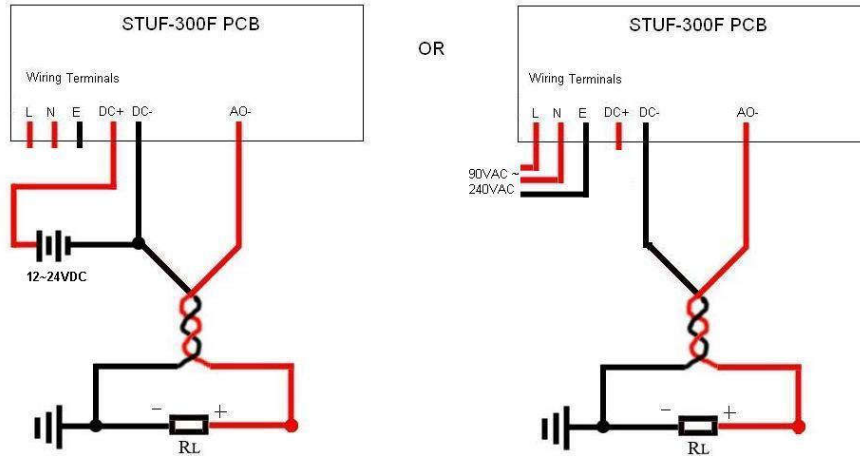

If you need isolated 40-20mA output, you need to add an external 12VDC/15VDC power and wire it as shown in Figure 3.1c.

4~20mA loop Powered

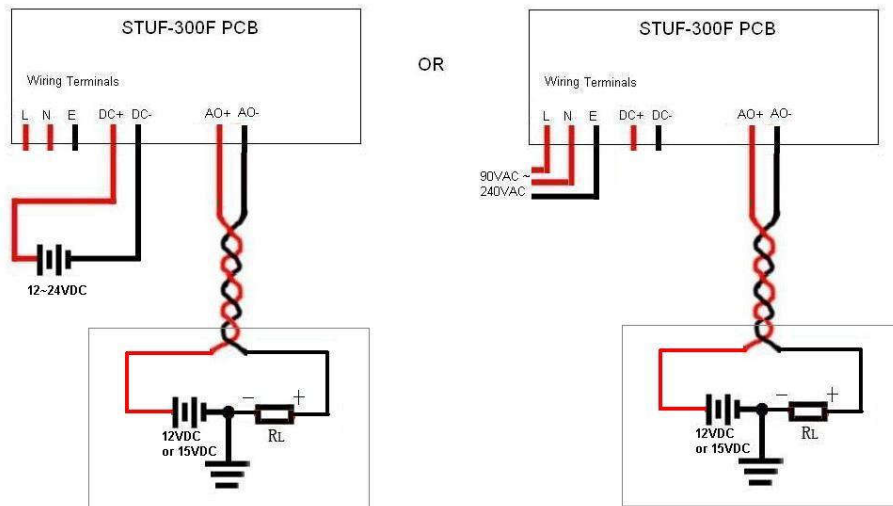

Figure 3.1c. 4-20mA wiring diagram - loop-powered method using external power supply

### §3.17 How to output analog voltage signal

Replace the load RL shown in Figure 3.1 with a 250Ohm/0.25W resistor. This resistor will convert the 4-20mA output current into 1-5V voltage signal. In other words, the voltage across the resistor will be 1-5V.

### §3.18 How to use the Frequency Output

When Frequency Output Module is equipped, the EF10 flowmeter can output a frequency signal which represents the instantaneous flow rate. This output is totally user-configurable. Usually, four parameters should be configured: frequency minimum and frequency maximum (M67), as well as corresponding flow rate lower limit and higher limit (M68 and M69).

For example, assume that the flow rate varies in a range from 0m<sup>3</sup>/h to 3000m<sup>3</sup>/h, and the required output signal frequency should be in a range from 200Hz to 1000Hz. The user should enter 0 in M68 and 3000 in M69, and enter 200 and 1000 in window M67.

Please note that the user needs to select the frequency output option (the 13<sup>th</sup> option, “FO output”) in window M78. The user must also make the OCT hardware connection to the device which is supposed to use the frequency output signal. Refer to Appendix §9.1 for wiring information.

### §3.19 How to use the Totalizer Pulse Output

The flowmeter is able to produce a pulse output every time when it reaches a unit flow of liquid. This pulse could be used by an external pulse counter to accumulate the flow rate.

Refer to §3.4 and §3.5 for the setup of the totalizer units and multiplier.

The totalizer pulse output can only be transmitted through OCT or relay devices. Therefore, it is necessary to configure the OCT or relay. This can be done in menu M78 and M79. Refer to the next chapter for detail on M78 and M79.

For example, assume that we need to output the POS totalizer through the relay in pulse form, and every pulse represents 0.1cubic meter of liquid flow. The following steps must be performed:

- (1) Select the Cubic Meter (m<sup>3</sup>) unit in window M32.
- (2) Select the Multiplier factor as ‘2. X0.1’ in window M33.
- (3) Select the output option ‘9. POS INT Pulse’ in window M77. (INT stands for integrated or totalized )

Note that the totalizer pulse must be set properly. It should be neither too large nor too small. If it is too large (e.g., long period), the output pulse will be very slow. If it is too small (e.g., short period), the relay may activate too frequently and its lifetime may be shortened. Besides, pulse loss error may occur. It is recommend to be within 1-60 pulse/minute. You can adjust the pulse period by selecting different totalizer multiplier factor in M33.



### §3.20 How to produce an alarm signal

There are two types of hardware alarms that are available with this instrument. One is the audible alarm, and the other is the ON/OFF output signal which can drive an alarm. The audible alarm is also called Buzzer. It is generated internally and can be configured in M77. The ON/OFF output signal is generated through the OCT or relay output which is connected to an external alarm circuitry.

The triggering sources of the alarming events for both the Buzzer and the ON/OFF alarm signal could be:

- (0) No Signal - There is no receiving signal.
- (1) Poor Signal - The signal received is too weak.
- (2) Not Ready - The flowmeter is not in normal measurement mode.
- (3) Reverse Flow - The flow direction is reversed.
- (4) AO Over 120% - Overflow occurs at the analog outputs by 120% or more.
- (5) AO Over 120% - Overflow occurs at the frequency output by 120% or more.
- (6) Alarm #1 - The flow rate is out of the specified upper and lower limits specified in Alarm#1 settings (windows M73 and M74).
- (7) Alarm #2 - The flow rate is out of the specified upper and lower limits specified in Alarm#2 settings (windows M75 and M76).
- (8) Batch Controller – Batching started.
- (9) POS Int Pulse – Positive totalizer pulse output.
- (10) NEG Int Pulse – Negative totalizer pulse output.
- (11) NET Int Pulse – Net totalizer pulse output.
- (12) Energy POS Pulse – Thermal energy positive totalizer pulse output.
- (13) Energy NEG Pulse – Thermal energy negative totalizer pulse output.
- (14) Energy NET Pulse – Thermal energy net totalizer pulse output.
- (15) MediaVel => Thresh – Liquid sound speed becomes bigger, over the preset threshold.
- (16) MediaVel <= Thresh – Liquid sound speed becomes smaller, lower than the preset threshold.
- (17) ON/OFF Via RS485 – RS485 is the trigger source, providing ON/OFF control.
- (18) Timer (M51 Daily) – Daily scheduler programmed in M51 is the trigger source.
- (19) Timer Alarm #1 – Alarm#1 is the trigger source during the time period specified in M51.
- (20) Timer Alarm #2 – Alarm#2 is the trigger source during the time period specified in M51.
- (21) Batch Total Full – The totalizer in the batch controller is full.
- (22) Key Stroking ON – Key stroke is the trigger source.

(23)Disable BEEPER – the BEEPER will not be activated.

Example A: assume we need the Buzzer to start beeping when the flowmeter is not ready in normal measurement. Switch to M77, select item “2. Abnormal Measurement State”

Example B: assume we need the Buzzer to start beeping when the flow rate is less than 300 m3/h and greater than 2000m3/h. The following setup steps would be recommended:

- (1) Enter flow rate lower limit 300 in M73 for #1 alarm,
- (2) Enter flow rate upper limit 2000 in M74 for #1 alarm,
- (3) Select item ‘6. Alarm #1’ in M77.

Example C: assume we need the OCT output to activate when flow rate exceeds 100~500m3/h and the relay output to activate when flow rate exceeds 600~1000m3/h. The following setup steps would be recommended:

- (1) Enter flow rate lower limit 100 in M73
- (2) Enter flow rate upper limit 500 in M74
- (3) Enter flow rate lower limit 600 in M75
- (4) Enter flow rate upper limit 1000 in M76
- (5) Select item ‘6. Alarm #1’ in M78
- (6) Select item ‘6. Alarm #1’ in M79.

### §3.21 How to use the OCT output

The OCT output is an ON/OFF type, electrically isolated collector open circuit output. It is user-configurable. You can program it to be an ON/OFF type alarm signal or a totalizer pulse signal.

Notice that the Frequency Output shares the same OCT hardware. When used as Frequency Output, the OCT cannot be used for other purpose (neither alarm signal nor totalizer pulse signal).

The OCT has two wiring terminals, terminals OCT+ and OCT-. Terminal OCT+ is collector and terminal OCT- is emitter. Be careful of the polarity. An external DC power supply Vcc and an external pull-up resistor Rx are needed for using the OCT (Figure 3.2). Vcc can be from +12VDC to +24VDC. Rx can be from 1KOhm to 10KOhm. The maximum current the OCT can take should be

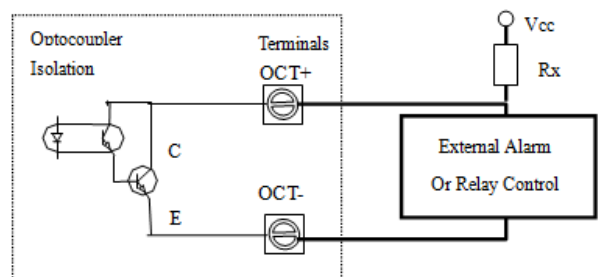

Figure 3.2 Wire the isolated OCT output to an external alarm device .

less than 0.2A. The OCT can drive an alarm, pulse counter, frequency counter, etc. It can also be used to drive a relay, which operates a valve system, for instance.

Refer to the next chapter on menu M78 for OCT configuration.

### §3.22 How to use the relay output

The relay output is a single-pole single-throw (SPST). It has two terminals, R+ (normally open, NC) and R- (common, C). Its maximum operating frequency is 1Hz. Its load current is 1A at 125VAC, or, 2A at 30VDC.

The relay output is user-configurable and can be configured as an ON/OFF type signal to drive an alarm or a valve, or, as a totalizer pulse signal to drive a remote counter or totalizer.

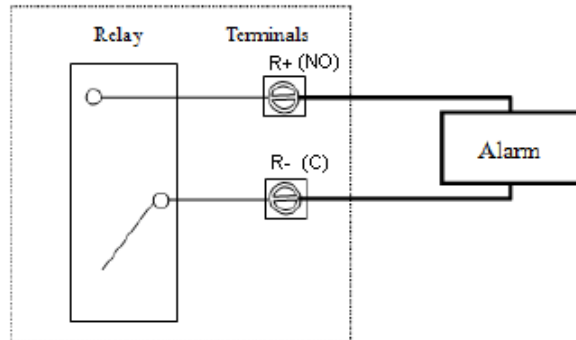

Figure 3.3 Wire the relay to an alarm device with Normally Open configuration.

When wiring the relay to an external device, you can wire it as normally open only. Figure 3.3 illustrates how to wire the relay to an external alarm with normally open configuration.

Please refer to the next chapter on menu M79 for more details.

### §3.23 How to use the built-in Buzzer

The built-in buzzer is user-configurable. It can be used as an alarm. Use M77 for setups.

### §3.24 How to modify the built-in calendar

The current date and time is displayed in menu M04 in format “yy-mm-dd hh:mm:ss”. If this is the first time you run the flowmeter, please do make sure that the date and time are correct. If not, please make correction. In addition, if “daylight saving” applies in your area, you may also need to change the time accordingly.

To make changes on the date and time, press **MENU** **6** **0** **ENT** to switch to menu M60 and modify the settings. Use the dot key to skip over these digits that need no modifications.

The calendar can also be modified through the serial port. Please refer to Chapter 6.

### §3.25 How to adjust the LCD

Use M70 to adjust the LCD backlight. Press **[MENU]** **[7]** **[0]** **[ENT]**. You should see “>” on the screen, which indicates that the system is ready for modification. Use **[↑/+]** and **[↓/-]** to select the desired option. “Always On” means that the backlight will remain on always. “Always Off” means that the backlight will remain off always. “Time=” means that the backlight will keep on for “x” seconds which should be keyed in after selecting “Time=”.

Use M71 to adjust the LCD contrast. This is necessary when the letters on the screen are not clear and the viewing angle is offset. Press **[MENU]** **[7]** **[1]** **[ENT]**. You should see “>” on the screen. Use **[↑/+]** and **[↓/-]** to increase or decrease the contrast.

### §3.26 How to use the RS-485 interface

The EF10 family flowmeters are equipped with a standard half-duplex RS-485 serial interface. The terminals for this port are Tx and Rx, therefore, only two wires are needed to connect a EF10 flowmeter to a RS-485 bus. The data rate of the RS-485 port can be set to 75-115,200 Baud in M62.

Please refer to Chapter 6 and Appendix §9.1 for more details.

### §3.27 How to view and reset the yearly/monthly/daily totalizers

In addition to the POS, NEG and NET totalizers shown in M34-M36, there are 128 DAILY totalizers, 64 MONTHLY totalizers and 5 YEARLY totalizers for net flow and energy totalization. In other words, the flowmeter records the net flow total and net energy total of the last 128 days, the last 64 months and the last 5 years.

To view those records, go to M82, select item 0 for “Day”, 1 for “Month” or 2 for “Year”. In the display window, the first line will be the data or the total working time. The second line will be the net flow or net energy total. You may also see “----” on the upper right corner, which indicates that the system was normal during that day, or, you may see “G”, “H” or other characters, which indicates errors occurred in that day. Please refer to chapter 5 for error code explanations and solutions.

Use M37 to reset the yearly/monthly/daily totalizers.

### §3.28 How to connect analog input signals

The EF10 could be expanded to support up to 5 analog channels, AI1-AI5. AI1 and AI2 channels are assigned to temperature measurement by using PT100 RTD sensor. The remaining three channels, AI3-AI5, are current input channels which can be connected to any standard 0/4-20mA transmitters, such as temperature transmitter, pressure transmitter, level transmitter, etc.

In the standard EF10 model, however, only one analog channel, AI3, is available. More input channels may be added upon request. In a thermal energy model, e.g., EF10Rx, the two temperature channels are enabled.

The input signal is digitized and acquired by the flowmeter. The data can then be sent to a remote computer or controller through RS-485 upon request. Refer to chapter 6 for communication details.

AI3 input terminal blocks are labeled AI3+ and AGND. Menu window M07 displays the input current values and their corresponding physical values. The terminals assigned to the two temperature inputs are TX1+, T1, TX2+, T2 and GND. Menu window M06 displays the input RTD resistances and their corresponding temperature values.

### **§3.29 How to compensate the flow not measured during offline**

When the power is down, the flowmeter will not be able to conduct flow measurement. In order to compensate the flow uncounted during the offline period, you need to enable Automatic Amending function before the flowmeter is offline.

To enable the Automatic Amending function, switch to M83, press  key, then, select YES and press  again.

To disable this function, just select OFF in menu M83.

Please note that there are many factors which could impact the reliability of this function in a complicate application. We do not recommend you to use this function. Instead, try to find an uninterruptible power supply (UPS).

Refer to the next chapter for M83 details and how the uncounted flow is estimated.

### **§3.30 How to use the Working Timer**

Use the working timer to check the time that has passed with a certain kind of operation.

The working timer value is displayed in M72. To reset the timer, press  key and select YES.

### **§3.31 How to use the manual totalizer**

Use M38 to use the manual totalizer. Switch to M38. Press  key to start, and press  key again to stop the totalizer.

This function is useful for conducting flowmeter calibration.

### **§3.32 How to use the batch process controller**

The EF10 has a built-in batch process controller. It can be used for flow quantity control or the

batching of specific volumes.

This batch controller utilizes the keypad or the rising edge or falling edge of an analog input signal as its control signal input (or triggering signal). It utilizes the OCT as its output. When using analog as the input signal, the input current must be larger than 2mA to indicate a logic “1” and 0mA to indicate a logic “0”.

The user needs to select the type of input control signal in menu M80. The user also needs to select the output type to be item 8 “output as batch controller” in M78 for OCT output or in M79 for relay output.

Use M81 to enter batch value. After completion, the display will be in batch control mode and the batch controller is waiting for triggering signal. If you selected “0. Key Input” as the triggering source in M80, you may press the **ENT** key to start the batch process. Otherwise, just wait the specified triggering event is detected.

By combing the batch function with the built-in scheduler, one can do batch delivery at a specific period of time for a certain number of times.

Example: assume one wants to deliver 5 m<sup>3</sup> of water to a client’s pipe, and repeat this every 2 hours until 50 m<sup>3</sup> has been delivered. After the completion of this process, the flowmeter should trigger an alarm which is connected to its OCT output. Assume the starting time is 9am (should be ahead of the current time). You may program the flowmeter as following:

In M51: Start Time 9:00:00; Interval 02:00:00; Repeat 10

In M78: select 8. Batching Controller

In M80: select option 8. Timer-periodical

In M81: enter 5

### §3.33 How to calibrate the 4-20mA current output

In general, there is no need to calibrate the analog output since it has been calibrated in factory. However, if you find the current value shown in M58 differs from the actual current shown in the ammeter, you do need to recalibrate the analog output.

Calibration steps:

First, put the flowmeter into calibration mode. Press **MENU** **-** **0** **ENT**, enter password “4213068”, and press **ENT** again.

Then, connect a precise ammeter to the current output loop.

Press **ENT** to calibrate the current loop 4mA output. Read the ammeter. If the reading is not 4mA, use **↑/+** or **↓/-** to adjust the output current until the ammeter reads 4.00mA.

Press **ENT** again to calibrate 20mA output, similar to the above step.

Press **MENU** **2** **6** to enter into window M26, press **ENT** **1** **ENT** to save the above configuration results into non-volatile memory.

### §3.34 How to check the ESN

Each product of the EF10 series has a unique electronic serial number (ESN) to identify itself. The user can use the ESN for instrumentation management.

The ESN is displayed in window M61.

Use M+1 to view the total working time since the instrument left the factory. Use M+4 to view the total number of times the instrument has been turned on and off since the instrument left the factory.

### §3.35 How to implement leakage detection

EF10 has powerful functions designed for leakage detection applications. By configuring menus M51, M73-M81, one can make the flowmeter enter into leakage detection mode at a specified period of time in a day, every day. When a leakage is detected, the flowmeter will trigger an alarm, or a relay which can be used by your security system.

Example: assume one wants to monitor a water pipe during night from 11pm to 5am daily. Under normal condition, there should have no flow in the pipe during this period of time. However, if the pipe is broken due to frozen, leakage happens. If the leakage flowrate is over 0.1m<sup>3</sup>/hour, one wants the flowmeter to send a signal to close his valve. Assume the valve is connected to a relay which is then connected to OCT2 output. The flowmeter should be programmed as following:

In M51: Start Time 23:00:00; Interval 06:00:00; Repeat 9999

In M73: enter -0.1 for the lower threshold of Alarm#1

In M74: enter 0.1 for the upper threshold of Alarm#1

In M79: select 19. Timer Alarm#1

For advanced leakage detection solution, such as dialer-based or GSM/GPRS-based leakage detection, please contact the manufacturer for more information.

For more application tips and help, please visit our technical support site at

<http://www.spiremt.com/support/stuf300.htm>.

## 4. Menu Window Details

Note 1: It is recommended to practice those menu windows on your flowmeter while reading this chapter for easy understanding.

Note 2: To quickly switch to a menu window, just press **MENU** followed by the window number (a two digit number). To move from one window to the next, use **↑/+** or **↓/-** key.

Note 3: After making changes to the flowmeter configuration parameters, please use M26 to save the changes into the non-volatile FLASH memory. The flowmeter will automatically load those parameters every time when power is up.

The FLASH memory can save and recall 9 groups of pipe parameters.

Menu Window No.	Function
M00	Display flow rate and net totalizers
M01	Display flow rate, velocity
M02	Display flow rate and positive totalizer
M03	Display flow rate and net totalizer
M04	Display date and time, flow rate
M05	Display total energy and energy rate
M06	Display temperatures, T1 and T2
M07	Display analog inputs AI3 and AI4
M08	Display all the detailed working status
M09	Display today's total flow
M10	Window for entering the outer perimeter of the pipe
M11	Window for entering the outer diameter of the pipe. 0 to 18000mm allowed
M12	Window for entering pipe wall thickness
M13	Window for entering the inner diameter of the pipe
M14	Window for selecting pipe material Standard pipe materials (users do not need to know the speed ) include: (0) carbon steel (1) stainless steel (2) cast iron (3) ductile iron (4) copper (5) PVC (6) aluminum (7) asbestos (8) fiberglass (9)others
M15	Window for entering the pipe material speed, only for non-standard pipe materials
M16	Window for selecting the liner material, select none for pipes without any liner. Standard liner materials that the user does not need to know the speed include: (1) Tar Epoxy (2) Rubber (3) Mortar (4) Polypropylene (5) Polystyryol (6)Polystyrene (7) Polyester (8) Polyethylene (9) Ebonite (10) Teflon (11) others
M17	Window for entering the liner material speed, only for non-standard liner materials
M18	Window for entering the liner thickness, if there is a liner
M19	Window for entering the ABS thickness of the inside wall of the pipe
M20	Window for selecting fluid type For standard liquids that the user does not need to know the liquid speed include:



EF10 Wall-Mount Ultrasonic Flowmeter

	(0) Water (1) Sea Water (2) Kerosene (3) Gasoline (4) Fuel oil (5) Crude Oil (6) Propane at -45C (7) Butane at 0C (8)Other liquids (9) Diesel Oil (10)Caster Oil (11)Peanut Oil (12) #90 Gasoline (13) #93 Gasoline (14) Alcohol (15) Hot water at 125C
M21	Window for entering the fluid sonic velocity, only for non-standard liquids
M22	Window for entering the viscosity of the non-standard liquids
M23	Window for selecting the proper transducers There are 16 different types of transducers for selection. If the user-type-transducer is selected, system will prompt another 4 user-type-wedge parameters to be inputted. If the PI-type transducer is selected, the system also needs another 4 PI type transducer parameters.
M24	Window for selecting the transducer mounting methods Four methods can be selected: (0) V-method (1) Z-method (2) N-method (3) W-method
M25	Display the transducer mounting spacing
M26	(0) Save the current configuration parameters into RAM. Not recommended for general users (1) Save the current configuration parameters into the non-volatile FLASH memory. <b>Recommended to use this function every time after you make changes on the flowmeter configurations</b>
M27	Entry to store or restore configuration parameters from the internal Flash memory. Up to 9 sets of configuration parameters are allowed.
M28	Select YES or NO for the instrument to determine whether or not to hold (or to keep) the last correct value when poor signal condition occurs (Q less than what is set in M.5). YES is the default setup.
M29	Pipe empty setup. Enter a value ranging from 00 to 99. 0 is the default value. When signal strength is below this value, the flowmeter will assume the pipe is empty and will not count the measuring results. It is recommended to set to 40 if you want to turn on this function. When pipe is empty, ultrasound may still travel from one transducer to another through pipe wall. The flowmeter may treat this as good signal and work as under normal condition. Using this menu setting will avoid this situation.
M30	Window for selecting unit system. Default value is 'Metric'. The change from English to Metric or vice versa will not affect the totalizer unit.
M31	Window for selecting flow rate that will be used by the instrument afterwards. Flow rate can be in 0. Cubic meter short for (m3) 1. Liter (l) 2. USA gallon (gal) 3. Imperial Gallon (igl) 4. Million USA gallon (mgl) 5. Cubic feet (cf) 6. USA oil Barrels (OB) 7. Imperial Oil Barrels (IB) The flow unit in terms of time can be per day, per hour, per minute, or per second. Thus there are 32 different flow rate units in total for selection.
M32	Window for selecting the totalizers' working unit
M33	Select totalizer multiplier The multiplier ranges from 0.001 to 10000
M34	Turn on or turn off the NET totalizer
M35	Turn on or turn off the POS totalizer
M36	Turn on or turn off the NEG totalizer
M37	(1) Totalizer reset (2) Restore the instrument to the default parameters as the manufacturer did by pressing the dot key followed by the backspace key. Take note of the parameters before doing the restoration
M38	Press a key to run or to stop totalizer
M39	Language selection
M40	Flow rate damper for a stable value. The input range is 0 to 999 seconds. 0 means there is no damping. Default value is 10 seconds
M41	Lower flow rate cut-off to avoid invalid accumulation.

M42	Zero Point setup or Zero calibration. Should be conducted when the flow in the pipe is totally stopped (zero flow velocity), but the pipe should still be full of liquids <b>After Zeroing, you need to save the Zero Point by visiting M.2 menu.</b> Please refer to M.2 item at the end of this table for details.
M43	Clear the zero point set by the user, and restore the zero point set by the manufacturer
M44	Set up a manual flow trend. In general this value should be 0.
M45	Scale factor for the instrument of certain transducer pair. If you ordered more than one pair of transducers, you need to change the value to the scale factor of the transducer pair in use. You are also recommended to do a Zero when change the transducer pair.
M46	Network Environment Identification Number. Any integer can be entered except for 13 (ODH, carriage return), 10 (0AH, line feeding), 42 (2AH), 38, 65535. Every set of the instrument in a network environment should have a unique ID number. Please refer to the chapter on communication.
M47	System locker to avoid modification of the parameters by mistake
M48	Entry to linearity correction data. As many as 12 data points can be entered.
M49	Display the input contents for the serial port.
M50	Turn on/off the data logging port Select the item to be logged or to be output through the 0/4-20mA analog output channel. Not recommended to change.
M51	The built-in Scheduler Three parameters: start time, interval and number of times to be repeated.
M52	(1) Data logging direction control. If 'To RS-485' is selected, all the data will be transmitted to the RS-485 port (2) If 'To the internal serial BUS' is selected, the data will be transmitted to the internal serial bus. If you flowmeter is equipped with a thermal printer or a 4-20mA analog output module, this selection must be chosen. Not recommended to change.
M53	Display the input current value and the converted value of analog input AI5.
M54	Pulse width setup for the OCT output.
M55	Select the current loop (CL) mode. Available options: 0. 4-20mA (set up flowrate output range from 4-20mA) 1. 0-20mA (set up flowrate output range from 0-20mA) 2. RS232 controls 0-20mA (set up to control by serial port RS-485) 3. 4-20mA vs. Sound (set up sound speed output range from 0-20mA) 4. 20-4-20mA (set up flowrate output range from 20-4-20mA) 5. 0-4-20mA (set up flowrate output range from 0-4-20mA) 6. 20-0-20mA (set up flowrate output range from 20-0-20mA) 7. 4-20mA vs. Vel (set up velocity output range from 4-20mA) 8. 4-20mA vs. Energy (set up thermal energy output range from 4-20mA)  The output current value is controlled by sending a parameterized command to the flowmeter through its RS-485 serial port. The command formats are explained in chapter 6. Example, if you want to output a 6mA current through the current loop, you need to select mode "0-20mA Via RS232/485" in menu M55 and send command "A06 (CR)" to the flowmeter. This function allows the flowmeter to control valve openness.  Other different current output characteristics are illustrated in the following figures. The user can select one of them according to his actual requirements. The minimum and maximum values indicated in the figure are those set in menu windows M57 and M58. In the 4-20mA and 0-20mA modes, the minimum and maximum can be a positive or negative flow value as long as the two values are not the

same. In the 20-4-20mA and 20-0-20mA modes, the polarity of the actual flow reading is ignored. In 0-4-20mA mode, the minimum must be negative, and the maximum must be positive.

The last one in the following figures is for velocity output. The output current represents flow velocity.

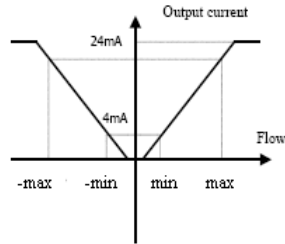

20-4-20mA Mode

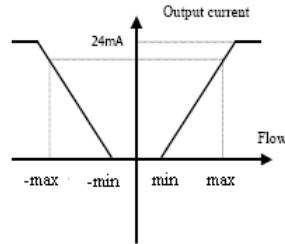

20-0-20mA Mode

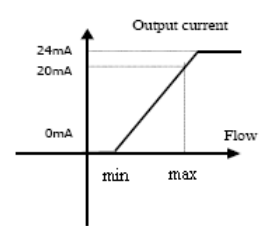

0-20mA Mode

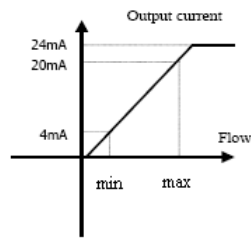

4-20mA Mode

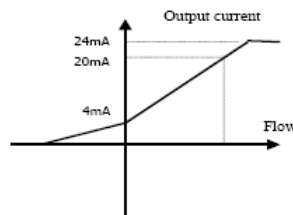

0-4-20mA Mode

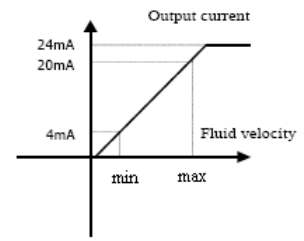

4-20mA Mode - Flow Velocity

M56	4mA or 0mA output value Set the flow rate value which corresponds to 4mA or 0mA output current (4mA or 0mA is determined by the settings in M55). The flow unit options are the same as those in M31. If “velocity 4-20mA” is selected in M55, the unit should be set to m/s.
M57	20mA output value Set the flow rate value which corresponds to 20mA output current. Refer to M31 for flow unit options.
M58	Current loop verification. Check if the current loop has been calibrated before leaving the factory. Press <b>[ENT]</b> , and use <b>[▼/+]</b> or <b>[▲/-]</b> to display 0mA, 4mA - 24mA one after another. For each one, check with an ammeter to verify that current loop output terminals agree with the displayed values. It is necessary to re-calibrate the current loop if over the permitted tolerance. For more information, refer to section §3.33 for analog output calibration.
M59	Display present output of the current loop circuit. Re-calibration is needed if the displayed value differs significantly from the actual output value measured with an ammeter.
M60	Set up system date and time. Press <b>[ENT]</b> for modification. Use the dot key to skip the digits that need no modification.
M61	Display Version information and Electronic Serial Number (ESN) that are unique for each STUF-300 series flow meter. Users can employ the ESN for instrumentation management
M62	RS-485 serial communication setup. Baud rate can be 75 to 115200 bps



EF10 Wall-Mount Ultrasonic Flowmeter

	<p>9. POS Int Pulse</p> <p>10. NEG Int Pulse</p> <p>11. NET Int Pulse</p> <p>21. Batch Total Full</p> <p>22. OCT NET Using</p>										
M79	<p>Relay (or OCT2) output setup</p> <p>Select a proper input source. The triggering sources are similar to those for OCT.</p> <p>When the trigger event of the selected source occurs, the relay output will change status, i.e., the C (Common) pin will be disconnected from NC (Normally Closed) pin and be connected to the NO (Normally Open) pin.</p>										
M80	<p>Signal selection for the built-in batch controller</p> <table style="width: 100%; border: none;"> <tr> <td style="width: 50%;">0. Key Pressing</td> <td style="width: 50%;">5. AI4 Falling Edge</td> </tr> <tr> <td>1. Serial Port</td> <td>6. AI5 Rising Edge</td> </tr> <tr> <td>2. AI3 Rising Edge</td> <td>7. AI5 Falling Edge</td> </tr> <tr> <td>3. AI3 Falling Edge</td> <td>8. Timer-periodical</td> </tr> <tr> <td>4. AI4 Rising Edge</td> <td>9. Timer-daily</td> </tr> </table>	0. Key Pressing	5. AI4 Falling Edge	1. Serial Port	6. AI5 Rising Edge	2. AI3 Rising Edge	7. AI5 Falling Edge	3. AI3 Falling Edge	8. Timer-periodical	4. AI4 Rising Edge	9. Timer-daily
0. Key Pressing	5. AI4 Falling Edge										
1. Serial Port	6. AI5 Rising Edge										
2. AI3 Rising Edge	7. AI5 Falling Edge										
3. AI3 Falling Edge	8. Timer-periodical										
4. AI4 Rising Edge	9. Timer-daily										
M81	The built-in batch controller										
M82	<p>Date totalizers by day, by month and by year. Use M37 to reset</p> <p>There are seven totalizers: Daily-totalizer for flow, Monthly-totalizer for flow, Yearly-totalizer for flow, Daily-totalizer for heat, Monthly-totalizer for heat, Yearly-totalizer for heat, and the Working-time-totalizer. The last one is the number of hours of continuous working under normal condition (no error condition) in the past day</p>										
M83	Automatic total flow correction switch										
M84	Energy unit selection.										
M85	Temperature selection										
M86	Specific Heat selection										
M87	Energy totalizer switch										
M88	Energy multiplier										
M89	Displays the current temperature difference (T1 - T2)										
M90	<p>Display signal strength and signal quality</p> <p>UP – upstream direction; DN – downstream direction; Q – signal quality</p>										
M91	<p>Displays the Time Ratio between the Measured Total Transit Time and the Calculated time. If the pipe parameters are entered correctly and the transducers are properly installed, the ratio value R should be in the range of 100±3%. Otherwise the entered parameters and the transducer installation should be checked.</p>										
M92	<p>Displays the estimated fluid sound velocity. If this value has an obvious difference from the actual fluid sound speed, pipe parameters and the transducer installation should be checked again.</p>										
M93	Displays total transit time and delta time (transit time difference)										
M94	Displays the Reynolds number and the pipe factor used by the flow rate program.										
M95	<p>(1) Display the positive and negative energy totalizer values and other menus in a loop fashion: M95-&gt;M00-M01-&gt;...M09-&gt;M90-&gt;95. Each menu is displayed for 8seconds. The loop-displaying will stop when any key is pressed.</p>										
<u>M96</u> none	Reserved for printer										
<u>M97</u> none	Reserved for printer										
<u>M98</u> none	Reserved for printer										
<u>M99</u> none	Reserved for printer										
M+0	Browse the 128 recorded instrument power-on and power-off dates and times with the flow rate at the time of power on and off										

EF10 Wall-Mount Ultrasonic Flowmeter

---

M+1	Displays the total work time of the instrument
M+2	Displays the last power-off date and time
M+3	Displays the last power-off flow rate
M+4	Displays how many times the instrument has been powered on
M+5	Calculator for the convenience of field working. All the values are in single accuracy.
M+6	MediaVel Threshold setup
M+7	Displays total flow for this month (up to today)
M+8	Displays total flow for this year (up to today)
M+9	Total time the flowmeter has not been in normal working mode. It includes the time when power is off.
M.2	Save Zero Point to the non-volatile FLASH memory. When a Zero calibration is done, you are recommended to save the Zero Point results by visiting this menu. You need to press <b>[ENT]</b> key, select YES and press <b>[ENT]</b> key again to save.
M.5	Set minimum quality Q for status “R”. When Q is less than this value, system status will be “Poor Signal”. Refer to M28.
M.8	The maximum flow rates for today and for the current month.
M-0	Entry to hardware adjusting windows only for the manufacturer

## 5. Troubleshooting

### §5.1 Introduction

The EF10 series flowmeters utilized high-reliability design, thus, their malfunction probability is quite low. However, due to improper settings, harsh environment or misuse, problem could occur. Therefore, EF10 is equipped with a complete set of self-diagnosis functions. The errors are displayed in the upper right corner of the menu window via identification code in a timely order. Hardware self-diagnosis is conducted every time when power is on. Some errors can even be detected during normal operation. For those errors undetectable due to incorrect settings or improper testing conditions, the flowmeter will also display useful information to help the user to quickly debug the error and solve the problem.

There are two types of errors, one is hardware error, and the other is operational error. Details are presented in the following sections.

### §5.2 Power-on Errors

When powered on, the EF10 series ultrasonic flowmeter automatically starts the self-diagnosis process to find if there are any hardware and software problems. If a problem is identified, an error message will be displayed. The following table shows the possible error messages, the corresponding causes and their solutions.

**Table 5.1 Hardware self-diagnosis errors and solutions**

Error message	Causes	Solutions
ROM Parity Error	ROM operation illegal / error	(1) Reboot the system (2) Contact the manufacturer.
Stored Data Error	User-entered parameters lost.	(1) Reboot the system (2) If problem persists, press ENT key to restore the factory default configuration.
SCPU Fatal Error	SCPU hardware fatal error	(1) Reboot the system (2) Contact the manufacturer.
System Clock Slow or Fast Error	Problem with the system clock or the crystal oscillator.	
CPU or IRQ Error	Problem with CPU or IRQ hardware	
System RAM Error	Problem with RAM chip	

Time Date Error	Problem with date/time chip	(1) Initialize the calendar in menu window M61. (2) Contact the manufacturer.
No Display. Erratic or Abnormal Operation	Problem with wiring	Double check wiring connections.
No response to key pressing	Keypad is locked Bad plug connection	Unlock the keypad.
Reboot repetitively	Hardware problems	Contact the manufacturer

### §5.3 Working Status Errors

The EF10 series ultrasonic flowmeter will show an Error Status Code (a single letter like I, R, etc.) in the upper right corner on menu windows. When any abnormal Error Code shows, counter-measures should be taken.

**Table 5.2 Working status errors and solutions**

<b>Error code</b>	<b>Message on window M08</b>	<b>Causes</b>	<b>Solutions</b>
<b>R</b>	System Normal	No error	
<b>I</b>	No Signal	(1)Unable to receive signal (2)Transducers installed improperly (3)Loosen contact or not enough couplant between transducer and pipe surface. (4)Pipe liners are too thick or the deposition inside of the pipe is too thick. (5)Transducer cables are not properly connected	(1)Polish the pipe surface and clean the spot. Remove paint. (2)Make sure the couplant is adequate (3)Make sure the transducer is in tight contact with pipe surface (4)Check the transducer cables (5)Check installation parameter settings (6)Find a better measurement site. Newer pipe, no corrosion, no deposition
<b>J</b>	Hardware Error	Hardware problem	Contact the manufacturer
<b>H</b>	Poor Sig. Detected	Poor signal detected Similar to error code I	Similar to error code I
<b>E</b>	Current Loop Over 20mA	4-20mA loop output over 120% Improper settings for current loop output	(1) Ignore it if current loop output is not used (2) Check current loop settings in M56. (3) Confirm if the actual flow rate is too high.
<b>Q</b>	Frequency Output Over	(1) The frequency output is 120% over. (2) Improper settings for frequency output	(1) Ignore it if frequency output is not used (2) Check the values entered in window M66, M67, M68 and M69.



		(3) The actual flow rate is too high	(3) Use a larger value in M69 if needed. (4) Confirm if the actual flow rate is too high.
<b>F</b>	System RAM Error Date Time Error CPU or IRQ Error ROM Parity Error	(1) Temporary problems with RAM, RTC (2) Permanent problems with hardware	(1) Reboot the system (2) Contact the manufacturer Refer to Table 5.1 as well
<b>G</b>	Adjusting Gain >s1 Adjusting Gain >s2 Adjusting Gain >s3 Adjusting Gain >s4 (shown in M00-M03)	Instrument is in the progress of adjusting the gain for the signal, and the number indicates the progressive steps	No need for action
<b>K</b>	Empty pipe	(1) No liquid inside the pipe (2) Incorrect setup in M29	(1) If the pipe is not full, relocate the meter to where the pipe is full of liquid (2) If the pipe is full, enter 0 in M29

### §5.4 Other Problems and Solutions

(1) Q: Why the instrument displays 0.0000 flow rate while the liquid in the pipe is actually flowing? The signal strength is checked to be good (the working status is “R”) and the signal quality Q has a satisfactory value.

A: The problem is likely to be caused by the incorrect “Zero Point” setting. The user may have conducted the “Zero Point” setup while the flow was not standstill. To solve this problem, use the ‘Reset Zero’ function in menu window M43 to clear the zero point.

(2) Q: The displayed flow rate is much lower or much higher than the actual flow rate in the pipe under normal working conditions. Why?

A: The entered offset value might be wrong. Enter ‘0’ offset in window M44.

(a) Incorrect transducer installation. Re-install the transducers carefully.

(b) The ‘Zero Point’ is wrong. Go to window M42 and redo the “Zero Point” setup. Make sure that the flow inside the pipe is standstill. No velocity is allowed during this setup process.

(3) Q: Why there is no signal? The installation requirements are met, pipe is new and pipe material is in good quality.

A: Check the following:

(a) Is the installation method suitable for your pipe size?

(b) Are the entered installation parameters correct?

(c) Are the wirings correct?

- (d) Adequate couplant? Are the transducers in good contact with pipe?
  - (e) Is pipe full?
  - (f) Is the transducer distance in consistency with the one shown in M25?
  - (g) Is transducer head/tail in the right direction?
- (4) Q: How to conduct measurement on an old pipe? Heavy scale inside, no signal or poor signal detected.
- A: (a) Check if the pipe is full of liquid.
- (b) Try Z method. If the pipe is close to a wall and it is hard to do Z-method installation, you may work on a vertical or inclined pipe with flow upwards.
- (c) Carefully select a good pipe section and fully polish/clean the installation area of the pipe surface. Apply a wide band of couplant on each transducer face. Install the transducer properly.
- (d) Slowly and slightly move each transducer with respect to each other around the installation point until the maximum signal is found. Be careful that the new installation location is free of scale inside the pipe and that the pipe is concentric (not distorted) so that the sound waves do not bounce outside of the proposed area.
- (e) For pipe with thick scale inside or outside, try to clean the scale off, if it is accessible from the inside. (Note: Sometimes this method might not work and sound wave transmission is not possible because of the layer of scale between the transducers and pipe inside wall).
- (5) Q: Why no current in the current loop output?
- A: Check if the current output mode is set correct in M55. You need to turn the current loop on in M55. Check the hardware connection: open the electronics enclosure, check to see if wires are properly connected to terminals AO+ and AO-.
- (6) Q: Why is the current output not correct?
- A: (a) Check if the current output mode is set correct in M55.
- (b) Check the upper and lower current settings in M56 and M57.
- (c) Re-calibrate the current loop. Verify the output with M49.
- (7) Q: Can the flowmeter work normally for a few years without stop under harsh environment where power supply voltage varies widely?
- A: Yes. EF10 flowmeter employed intelligent signal processing algorithms to handle strong interference coming from either power line or radiation. It also automatically adjusts itself to the optimal operation status when sound wave strength varies due to changing environment.

For more tips, please go to <http://www.spiremt.com/support/>.

## 6. Communication Protocol

### §6.1 General

The EF10 series ultrasonic flowmeter has integrated a standard isolated RS-485 communication interface to allow the flowmeter to be easily connected to a RS-485 network bus. The RS-485 interface is a two-wire, half-duplex serial interface, supporting MODBUS protocol as well as Spire Metering Extended Flowmeter Communication Protocol (EFCP). MODBUS is a common industrial communication protocol. It comes with two formats, MODBUS-ASCII and MODBUS-RTU. Both are supported by EF10.

You may also use our GSM/GPRS module to transmit flow data to a remote computer, or, to check the flow data and flowmeter status from your cell phone.

When using the flowmeter for networking, you may use the flowmeter's ID as its network address, and use [W]-extended command set as the communication protocol. The 4-20mA current loop output and OCT output can be used to control analog-based or stepper-based valve openness, and the relay output can be used to turn on and off other devices. The analog inputs can be used to input pressure, temperature and other signals. In brief, a EF10 is a complete flow measurement RTU or thermal energy measurement RTU.

The maximum transmission distance is 1000m for RS-485. If longer distance is needed, current loop, MODEM, GSM/GPRS can serve the purpose.

All the flowmeter operations can be made on a remote computer, except the modification of ID which can only be done locally through the flowmeter's keypad. The communication protocol is based on master-slave principle. Master (remote computer) sends a command, slave (the flowmeter) responses the command.

You may use the Hyper Terminal utility in your computer to send commands to and view responses from the flowmeter. Please refer to your computer's manual on how to configure the Hyper Terminal utility. Note that the COM port settings of your computer need to match those in the flowmeter (M62.)

By default, the RS485 will be setup with 9600, none, 8, 1 (9600 Baud, none parity, 8 data bits, 1 stop bit).

You may also use Spire Metering's software for the same purpose. Please check our website for latest software release.

## §6.2 RS-485 Wiring

If your master unit (a computer, a PLC or other controllers) does not have a RS-485 port, you need to buy a RS-232/RS-485 converter or a USB/RS-485 converter in order to connect your EF10 main unit to the master unit.

Figure 6.1 illustrates an example of a flowmeter network based on RS-485 bus. The 120Ohm resistor is recommended to be connected at the end of the bus if the length of the wires is long. If you simply connect the flowmeter to your PC though a 485 converter, you do not need to have this resistor.

To complete the wiring, follow those steps:

- Disconnect the main power to the unit and remove the cover.
- Install the required cable clamp in the chosen conduit hole on the bottom of the electronics enclosure.
- Feed one end of the cable through the conduit hole, wire it to terminal pins Tx and Rx , then, secure the cable clamp. Connect the other end of the cable to the 485 converter.
- Wire the 485 converter according to the its instructions
- Reinstall the rear cover on the enclosure and tighten the set screw.

Please refer to Appendix §9.1 for more information.

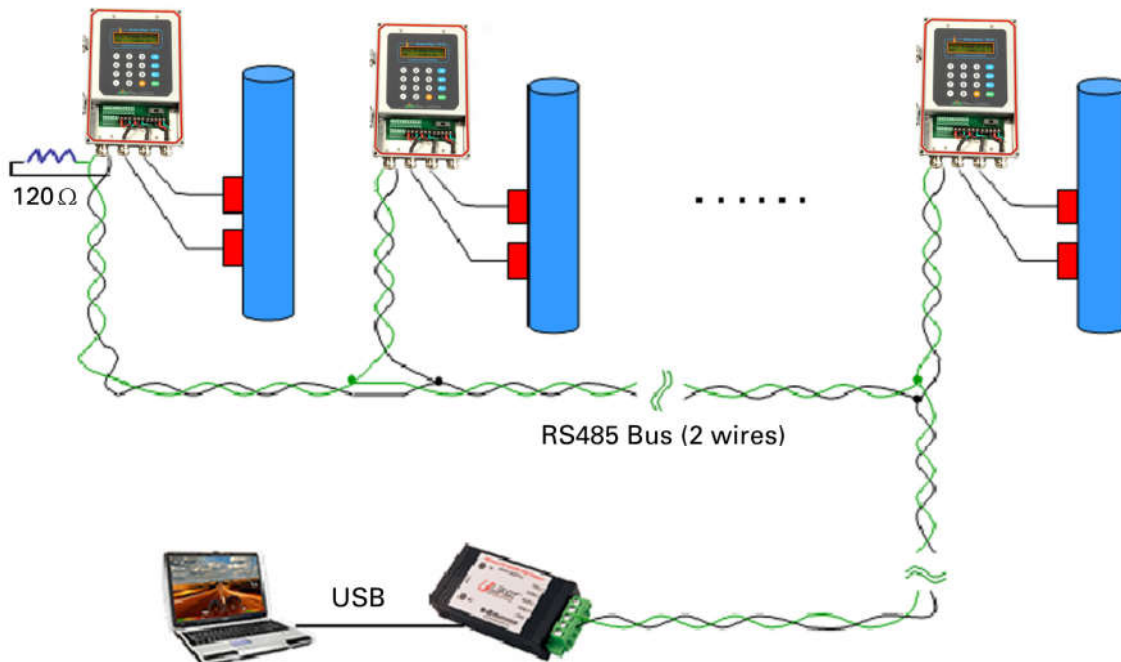

Figure 6.1 Flowmeter network based on RS-485 bus

### §6.3 MODBUS Protocol

Both MODBUS -ASCII and MODBUS -RTU protocols are supported. You may use menu window 63 (M63 hereafter) to select which protocol to use. The default is MODBUS-ASCII protocol.

Amount all the MODBUS functions, only function code 03, code 06 and code 16 are supported. Code 03 and code 06 are used to read from and write to a single register, and code 16 is used to write a block of registers. With RTU protocol, the maximum number of registers can be read at one time is 125, but with ASCII protocol, this maximum number is 61 only.

*Example 1:* we want to use MODBUS –RTU protocol to read flow velocity (REG 5 and REG 6) from flowmeter unit #1.

Select MODBUS-RTU in M63. Send the following command to RS485 bus where flowmeter unit#1 is connected:

<b>01</b>	<b>03</b>	<b>00 04</b>	<b>00 02</b>	<b>85 CA</b>	<b>(Hex)</b>
Unit#	Function Code	Start REG	# of REGs	Check-sum	

Here 85 CA is the hex value of the check-sum, which is calculated according to CRC-16 (BISYNCH, polynomial  $x^{16} + x^{15} + x^2 + 1$ , logical exclusive word 0A001H). Please refer to MODBUS standards for details.

The response to the above command will be (assume velocity is 1.2345678m/s):

<b>01</b>	<b>03</b>	<b>04</b>	<b>06 51 3F 9E</b>	<b>3B 32</b>	<b>(Hex)</b>
Unit#	Function Code	# of bytes	Velocity Data	Check-sum	

Here 3F 9E 06 51 represents velocity data 1.2345678, single-precision float format.

*Example 2:* we want to use MODBUS –RTU protocol to read net flow total (REG 25 and REG 26) from flowmeter unit #1.

Select MODBUS-RTU in M63. Send the following command to RS485 bus where flowmeter unit#1 is connected:

<b>01</b>	<b>03</b>	<b>00 18</b>	<b>00 02</b>	<b>44 0C</b>	<b>(Hex)</b>
Unit#	Function Code	Start REG	# of REGs	Check-sum	

The response to the above command will be (assume the net total is 802609, i.e., 00 0C 3F 31 in hex):

<b>01</b>	<b>03</b>	<b>04</b>	<b>3F 31 00 0C</b>	<b>A7 ED</b>	<b>(Hex)</b>
Unit#	Function Code	# of bytes	Velocity Data	Check-sum	

Please pay attention to the order of data.

*Example 3:* we want to use MODBUS –ASCII protocol to read REG 1 to REG 10 from flowmeter unit #1.

Select MODBUS-ASCII in M63. Send the following command to RS485 bus where flowmeter unit#1 is connected:

**:0103000000AF2 (CR and LF)**

Here “:” is the lead character of the MODBUS-ASCII protocol, “F2” is a two bytes checksum, computed by binary summing the ASCII code of all the characters before the checksum byte but not include the lead character.

Note: When debug the MODBUS protocol code, you may use MODSCAN tool which is free and can be downloaded from website.

***For MODBUS REGISTERS TABLEs, Please refer “STUF300 - ModbusReg.pdf”***

### §6.4 Extended Flowmeter Communication Protocol (EFCP)

The EF10 uses an Extended Flowmeter Communication Protocol compatible with our previous version ultrasonic flow meter, except for the commands in *Italic* in the following table.

Command	Meaning	Data format
DQD(cr) <i>note 0</i>	Returns flow rate per day	±d.dddddE±dd(cr) <i>note 1</i>
DQH(cr)	Returns flow rate per hour	±d.dddddE±dd(cr)
DQM(cr)	Returns flow rate per minute	±d.dddddE±dd(cr)
DQS(cr)	Returns flow rate per second	±d.dddddE±dd(cr)
DV(cr)	Returns fluid velocity	±d.dddddE±dd(cr)
DI+(cr)	Returns positive totalizer	±ddddddE±d(cr) <i>note 2</i>
DI-(cr)	Returns negative totalizer	±ddddddE±d(cr)
DIN(cr)	Returns net totalizer	±ddddddE±d(cr)
DIE(cr)	Returns net energy totalizer	±ddddddE±d(cr)
DIE+(cr)	Returns positive energy totalizer	±ddddddE±d(cr)
DIE-(cr)	Returns negative energy totalizer	±ddddddE±d(cr)
<i>DIT(cr)</i>	<i>Returns net total flow for today</i>	<i>±ddddddE±d(cr)</i>
<i>DIM(cr)</i>	<i>Returns net total flow for this month</i>	<i>±ddddddE±d(cr)</i>

EF10 Wall-Mount Ultrasonic Flowmeter

<i>DIY(cr)</i>	Returns net total flow for this year	$\pm d d d d d d d E \pm d (cr)$
DID(cr)	Returns the ID number/address	dddd(cr) 5 bytes long
E(cr)	Return energy flow rate per hour	$\pm d . d d d d d d E \pm d d (cr)$
DL(cr)	Returns the signal strength	UP:dd.d, DN:dd.d, Q=dd(cr)
DS(cr)	Returns percentage of AO output	$\pm d . d d d d d d E \pm d d (cr)$
DC(cr)	Returns current error code	Note 3
DA(cr)	OCT and RELAY output	TR:s, RL:s(cr) <sup>note 4</sup>
DT(cr)	Returns the current date and time	yy-mm-dd, hh:mm:ss(cr)
<i>Time@TDS1=(cr)</i>	Set date and time yy-mm-dd, hh:mm:ss	
M@(cr)	Mimic key input. @ presents a key	M@(cr) <sup>note 5</sup>
LCD(cr)	Returns current window display	
<i>LOCK0(cr)</i>	Unlock the system	Has nothing to do with the original password.
<i>LOCK1(cr)</i>	Lock the system	Can be opened by pressing the ENT key
<i>MENUXX(cr)</i>	Go to window XX	
C1(cr)	OCT turns on	
C0(cr)	OCT turns off	
R1(cr)	RELAY(OCT2) turns on	
R0(cr)	RELAY(OCT2) turns off	
FOddd(cr)	Output n Hz at frequency output	Fddd(cr)(lf)
AOa(cr)	Output a mA current at AO output	AOa(cr)(lf) <sup>Note 6</sup>
BA1(cr)	Return the resistance for T1	$\pm d . d d d d d d E \pm d d (cr)(lf)$
BA2(cr)	Return the resistance for T2	$\pm d . d d d d d d E \pm d d (cr)(lf)$
BA3(cr)	Returns the current (0~20mA) at AI3	$\pm d . d d d d d d E \pm d d (cr)(lf)$
BA4(cr)	Returns the current (0~20mA) at AI4	$\pm d . d d d d d d E \pm d d (cr)(lf)$
BA5(cr)	Returns the current (0~20mA) at AI5	$\pm d . d d d d d d E \pm d d (cr)(lf)$
AI1(cr)	Returns the temperature at T1 input	$\pm d . d d d d d d E \pm d d (cr)(lf)$
AI2(cr)	Returns the temperature at T2 input	$\pm d . d d d d d d E \pm d d (cr)(lf)$
AI3(cr)	Returns the value for AI3	$\pm d . d d d d d d E \pm d d (cr)(lf)$
AI4(cr)	Returns the value for AI4	$\pm d . d d d d d d E \pm d d (cr)(lf)$
AI5(cr)	Returns the value for AI5	$\pm d . d d d d d d E \pm d d (cr)(lf)$
ESN(cr)	Returns the ESN number	dddddd(cr)(lf) note 7
N	Prefix for single byte addressing network	Note 8
W	Prefix for ID string addressing network	Note 8
P	Prefix to returns with check-sum	
&	Command connector to make a super command in one line.	Result commands should not exceed 253 bytes long.

RING(cr)(lf)	Command for modem handshake	ATA(CR)(lf)
OK(cr)	Output by a modem	
	Output by flow meter to handshake a modem	AT(CR)(LF)
GA(cr)	Special command for GSM network.	note 9
GB(cr)	Special command for GSM network.	note 9
GC(cr)	Special command for GSM network	note 9

Notes:

0. (cr) is carriage return. Its ASCII value is 0DH. (lf) is line feed, and its ASCII value is 0AH.
1. 'd' stands for digit 0~9. A value of 0 is presented by +0.000000E+00
2. 'd' stands for digit 0~9. There is no dot before 'E'.
3. 1~6 characters present the current state of the flow meter. See the meaning of the characters in the chapter Diagnostics.
4. 's' presents one of ON, OFF or UD  
For example 'TR:ON,RL:ON' stands for that the OCT and RELAY are in ON state.  
'TR:UD,RL:UD' stands for that the OCT and RELAY are not assigned.
5. @ is the key value. For example, 30H stands for the '0' key. The command 'M4(cr)' acts just like the number 4 key on the keypad.
6. 'a' stands for the output current. The maximum value should not exceed 20. For example AO2.34567, AO0.2
7. 'ddddddd' stands for the Electronic Serial Number
8. If there are more than one flow meter or other kinds of meters in a network, a prefix like 'N' or 'W' must be added before the basic command in the above table, otherwise the system might be confused.
9. The returns by the special command for GSM networks contain Chinese characters.

### §6.4.1 Command prefixes and the command connector

(1) The P prefix

The P prefix can be added before every basic command to make the returned message with a check-sum. The check-sum is obtained by a binary addition. For example, if the command DI+(CR) (44H,49H,2BH,0DH in binary numbers brings a return like +1234567E+0m3 (CR) (2BH, 31H, 32H, 33H, 34H, 35H, 36H, 37H, 45H, 2BH, 30H, 6DH, 33H, 20H, 0DH, 0AH in binary numbers), then the PDI+(CR) will bring a return like +1234567E+0m3 !F7(CR). After the exclamation point '!' are the check-sum in ASCII format (2BH+31H+32H+33H+34H+35H+36H+37H+45H+2BH+30H+6DH+33H+20H=(2)F7H)

Please note that there may be no characters or only spaces before the exclamation point '!'.

(2) the N prefix

The use of prefix N goes like: N + single byte address + basic command.  
For example, if the address number 88 flow meter is going to be addressed, the command should be: NXDV(CR), the decimal value of X being 88.

The prefix W is strongly recommended for new users.

(3) The W prefix



Usage: W + character string address + basic command

The value of the character string should have a value in the range of 0~65535, except for the value of 13 (0DH carriage return), 10 (0AH line feed ), 42 (2AH \*), 38 (26H&) .

For example, if the velocity of number 12345 flow meter is wanted, the command can be like: W12345DV(CR), (57H, 31H, 32H, 33H, 34H, 35H, 44H, 56H, 0DH in binary numbers)

(4) The command connector &

The command connector ‘&’ adds several basic commands into a one-line super command. The super command should not exceed 253 characters. The prefix P should be added before every basic command for the returned results to have a check-sum.

For example, if the 1) flow rate 2) velocity 3) positive totalizer 4) net energy totalizer 5) the AI1 input 6) the AI2 input of the address number 4321 flow meter are required to return with check-sum, the one-line command should be:

W4321PDQD&PDV&PDI+&PDIE&PBA1&PAI2(CR)

The returned data are:

+0.000000E+00m3/d!AC(CR)

+0.000000E+00m/s!88(CR)

+1234567E+0m3 !F7(CR)

+0.000000E+0GJ!DA(CR)

+7.838879E+00mA!59

+3.911033E+01!8E(CR)

### §6.4.2 Key Value Table

The key values are used in a network application. By use of the key value and a command ‘M’, we can operate the flow meter through the network on a computer or other kinds of terminals. For example, the command ‘M0 (cr)’ acts just like the Zero key on the keypad.

key	Key value (hexadecimal)	Key value (decimal)	ASCII value	key	Key value (hexadecimal)	Key value (decimal)	ASCII value
0	30H	48	0	8	38H	56	8
1	31H	49	1	9	39H	57	9
2	32H	50	2	.	3AH	58	:
3	33H	51	3	◀	3BH	59	;
4	34H	52	4	MENU	3CH	60	<
5	35H	53	5	ENT	3DH	61	=
6	36H	54	6	▲/+	3EH	62	>
7	37H	55	7	▼/-	3FH	63	?

### §6.4.3 Programming Examples

Example 1: VB requests the instantaneous (in second) flow rate.

VB Code: `mscom1.input = "dqs" + vbcrLf;`

Example 2: VB requests the 4321 flowmeter to return the following data with checksum: (a) instantaneous flow rate; (b) instantaneous flow velocity; (c) Positive totalizer value; (d) Heat totalizer value; (e) AI1 input current; (f) AI2 input current.

VB Code: `mscom1.input = "W4321PDQD&PDV&PDI+&PDIE&PBA1&PAI2" + vbcrLf;`

Example 3: VB requests to change the pipe OD to 345mm.

VB Code: `mscom1.input = "M<" + vbCRLF + "M1" + vbCRLF + "M1" + vbCRLF + "M3" + vbCRLF + "M4" + vbCRLF + "M5" + vbCRLF + "M=" + vbCRLF`

Note that "M<" represents the MENU key, "M=" represents the ENT key, "M1" represents the "1" key.

## 7. Measurements of Thermal and Other Physical Parameters

### §7.1 Introduction

The EF10 flowmeter can be equipped with a maximum of two temperature measurement channels and three analog input channels.

The two temperature channels, which are available in model EF10Rx, can accommodate two PT100 RTD sensors directly. They are used for thermal energy measurement as will be introduced in the next section.

There is only one analog input channel in standard EF10 model, but can be extended to three channels upon request. These channels can be connected to analog sensors which output is in standard 4-20mA current to measure physical quantities, such as temperature, pressure, concentration, sulfa, etc. By combining the flow rate information, EF10 can provide very valuable information for resources management and process control.

All the results can be sent to a master computer through the RS-485 serial port. This means that a EF10 can be used as a RTU in a flow monitoring network. It helps to reduce the cost and complexity while improving the reliability of a monitoring network.

Note that the analog-to-digit conversion resolution of these analog channels is 12-bit, and there is no electrical isolation for those input channels. If the working environment is subjected to strong interference, it is recommended to add external isolation to protect the flowmeter device.

### §7.2 Wiring Analog Inputs

The two temperature channels designed for thermal measurement function are wired to terminal block pins TX1, T1, TX2, T2 and GND. They can work with a 3-wire or 4-wire PT100 sensor without any extra parts.

AI3 is a standard 4/0-20mA analog input channel, which can be used to accommodate temperature sensor, pressure sensor or other physical sensor. It is wired to terminal block pins AI3 and AGND

The wiring diagram is shown in the figure below.

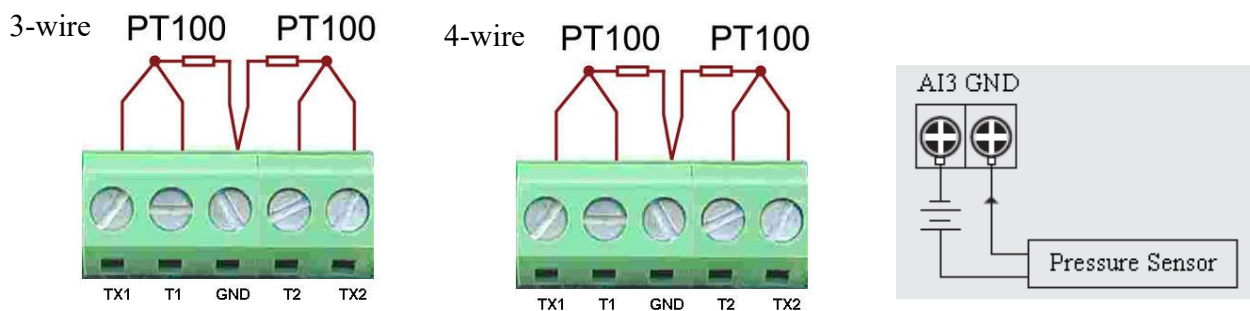

Menu window M06 and M+8 display the temperature measurement results. M07 displays the analog input current and its corresponding pressure or temperature value.

### §7.3 Thermal Energy Measurement

There are two methods for thermal energy calculation:

$$(1) Q_t = Q \times (T_2 - T_1) \times C_t,$$

$$(2) Q_t = Q \times (TC_2 - TC_1)$$

Where  $Q_t$  is the thermal energy (or caloric) consumed,  $Q$  is the flow rate,  $T_1$  and  $T_2$  are the temperature at supply and return points, respectively.  $C_t$  is the specific heat (or the thermal capacity coefficient) of the fluid, which can be entered in menu M86. For water, it is normally about 0.0041868GJ/m<sup>3</sup>°C.  $TC_1$  and  $TC_2$  are the thermal capacities corresponding to temperature  $T_1$  and  $T_2$ , which are calculated by the flowmeter according to international standards and displayed in M05.

The following menu windows might be used when performing thermal energy measurement:

Menu window M05: display energy and totalized energy.

Menu window M06: display the two temperature measurement results.

Menu window M07: display the values of input current AI3 and AI4 and their corresponding physical values.

Menu window M84: thermal unit selection.

KCAL/s - Kilocalories/second, GJ/s – Giga Joules/second

Menu window M85: temperature source selection: 0. temperature from input AI1 and AI2; 1. fixed difference. When selecting fixed difference, enter the difference in this menu.

Menu window M86: specific heat (or thermal capacity coefficient) input

Menu window M87: thermal totalizer on/off switch

Menu window M88: thermal totalizer multiplier factor

Menu window M89: thermal totalizer reset

Note that, if the fluid temperatures at both supply and return points are stable, you may choose not to use temperature transmitters. Instead, you can directly enter the temperature difference of the two points on menu window M85.

### §7.4 Configure Analog Measurement Ranges

Temperature, pressure and other physical signals can be entered into the flowmeter through analog

channels AI3-AI5, if these sensors provide standard 4-20mA signals. Their measurement ranges can be set on windows M64-M66. The first number of these windows is the minimum of the measurement range, corresponding to an analog input of 4mA. The second number is the maximum, corresponding to 20mA input current.

Example: assume a pressure transmitter outputs current 4mA at 0.98kg pressure and 20mA at 10.5kg pressure. The transmitter is connected to channel AI3. Then, you need to enter 0.98 and 10.5 in window M65. The present values of input current and corresponding temperature are shown in M07.

If you find the current value from the transmitter is different from the one shown in M07, you need to calibrate the corresponding analog channel. Please see section §3.16 for calibration detail.

### **§7.5 Read Input Analog Values from a Network Computer**

When the flowmeter is networked, all the analog data can easily be visited from a remote computer.

Use command BA1, BA2, BA3, BA4 and BA5 to read analog input current values of channel T1, T2, AI3, AI4 and AI5. Use command AI1, AI2, AI3 AI4 and AI5 to read the corresponding physical quantities of the five analog channels.

## **8. Warranty and Service**

### **§8.1 Warranty**

The products manufactured by Spire Metering are warranted to be free from defects in materials and workmanship for a period of one year from the date of shipment to the original purchaser. Spire Metering's obligation should be limited to restoring the meter to normal operation or replacing the meter, at Spire Metering's choice, and shall be conditioned upon receiving written notice of any alleged defect within 10 days after its discovery. Spire Metering will determine if the return of the meter is necessary. If it is, the user should be responsible for the one-way shipping fee from the customer to the manufacturer.

Spire Metering is not liable to any defects or damage attributable to misuse, improper installation, out-of-spec operating conditions, replacement of unauthorized parts and acts of nature. Besides, fuses and batteries are not part of this warranty.

THE FOREGOING WARRANTY IS EXCLUSIVE AND IN LIEU OF ALL OTHER EXPRESS OR IMPLIED WARRANTIES (INCLUDING BUT NOT LIMITED TO WARRANTIES OF MERCHANTABILITY AND FITNESS FOR A PARTICULAR PURPOSE, AND WARRANTIES ARISING FROM DEALING, TRADE OR USAGE.)

### **§8.2 Service**

The manufacturer provides instrument installation for its customers, and the charge will depend on the complexity of the installation.

For operational problems, please contact the technical support department by telephone, fax, email or internet. In most cases, problems could be solved immediately.

For any hardware failure of the instrument, we recommend our customers to send back the instrument for service. Please contact the technical support department with the model number and serial number of the unit before sending the unit back to us. Both numbers can be found on the product label. For each service or calibration request, we will issue a Return Materials Authorization (RMA) number.

Take notice that the cost for repairing can only be determined after receipt and inspection of the instrument. A quotation will be sent to the customer before proceeding with the service.

### **Important Notice for Product Return**

Before returning the instrument for warranty repair or service, please read the following carefully:

1. If the return item has been exposed to nuclear or other radioactive environment, or has been in contact with hazardous material which could pose any danger to our personnel, the unit cannot be serviced.

2. If the return item has been exposed to or in contact with dangerous materials, but has been certified as hazard-free device by a recognized organization, you are required to supply the certification for the service.
3. If the return item does not have a RMA# associated, it will be sent back without any service conducted.

### **§8.3 Software Upgrade Service**

We provide free-of-charge software upgrade services. Please contact the manufacturer for the software upgrade information. You may also go to our technical support website at <http://www.spiremt.com/support/ef10.htm> for the latest download.

## 9. Appendix

### §9.1 Wiring Diagram and Outline Drawings

The terminal blocks are labeled in the following figure. Please identify them correctly before starting wiring.

**WARNING!**  
**Disconnect power before wiring. Otherwise, the on-board electronics may be damaged by misconnecting or static discharge!**

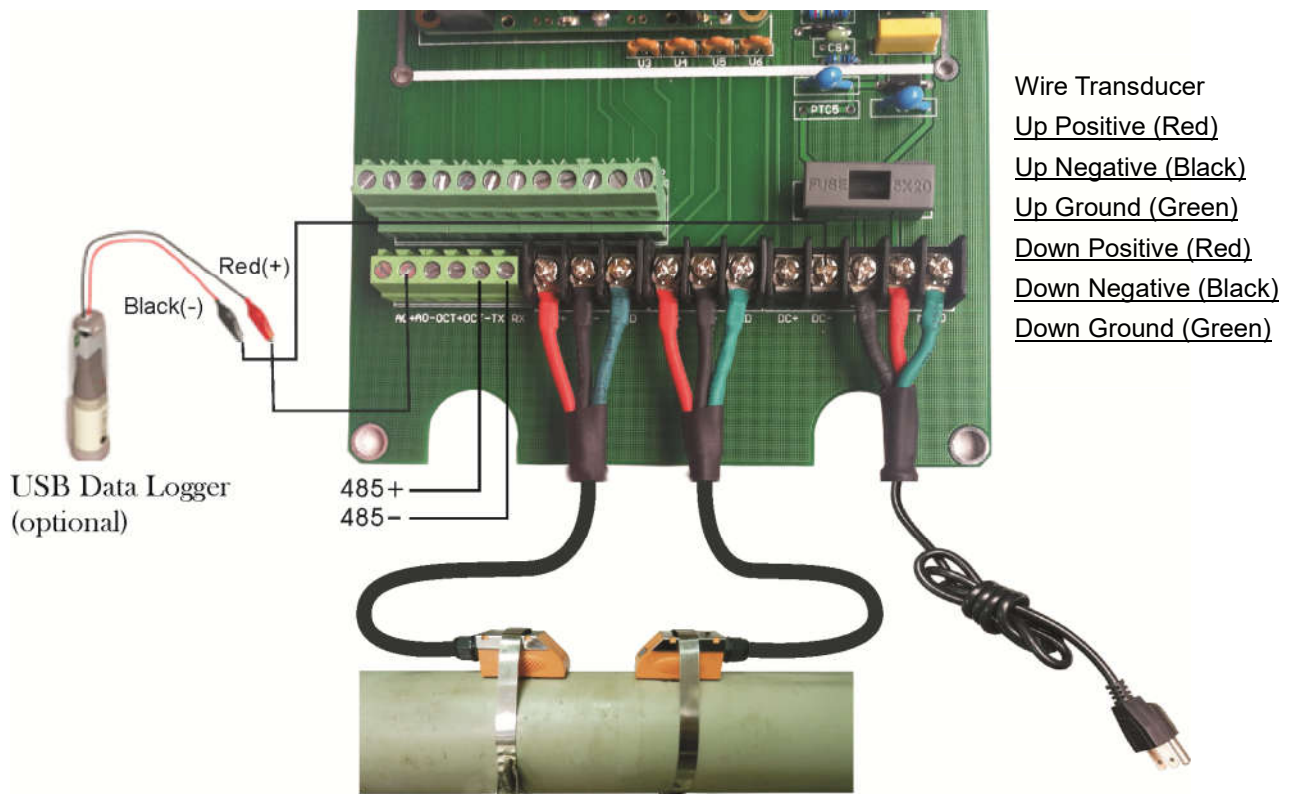

*\*Note: If you have ordered USB data logger, you need to program the data logger with your computer first before wiring it to the flowmeter unit. Otherwise, the data logger will not log data.*



**Line Voltage and Fuse Ratings:**

Line voltage is 90VAC~260VAC.

Fuse rating is 0.5A/250VAC, Slo-Blo.

Instead of AC power supply, you may also use 12VDC~32VDC power supply.

**WARNING!**

**Disconnect power before removing fuse.**  
**Be careful not to touch the on-board electronic parts when you replace the fuse. Otherwise, they may be damaged by static discharge!**

**Enclosure Outline**

**Standard Enclosure (EF10-x-A)**

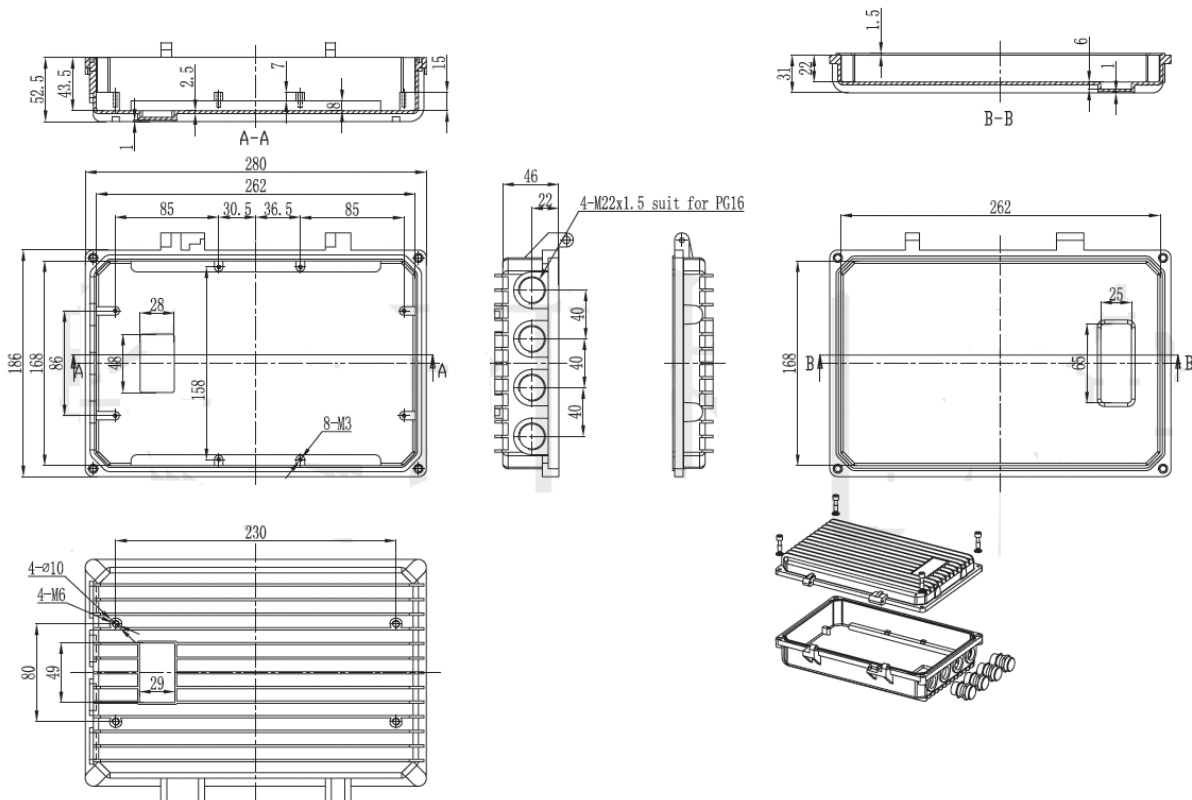

**Enhanced Enclosure (EF10-x-B)**

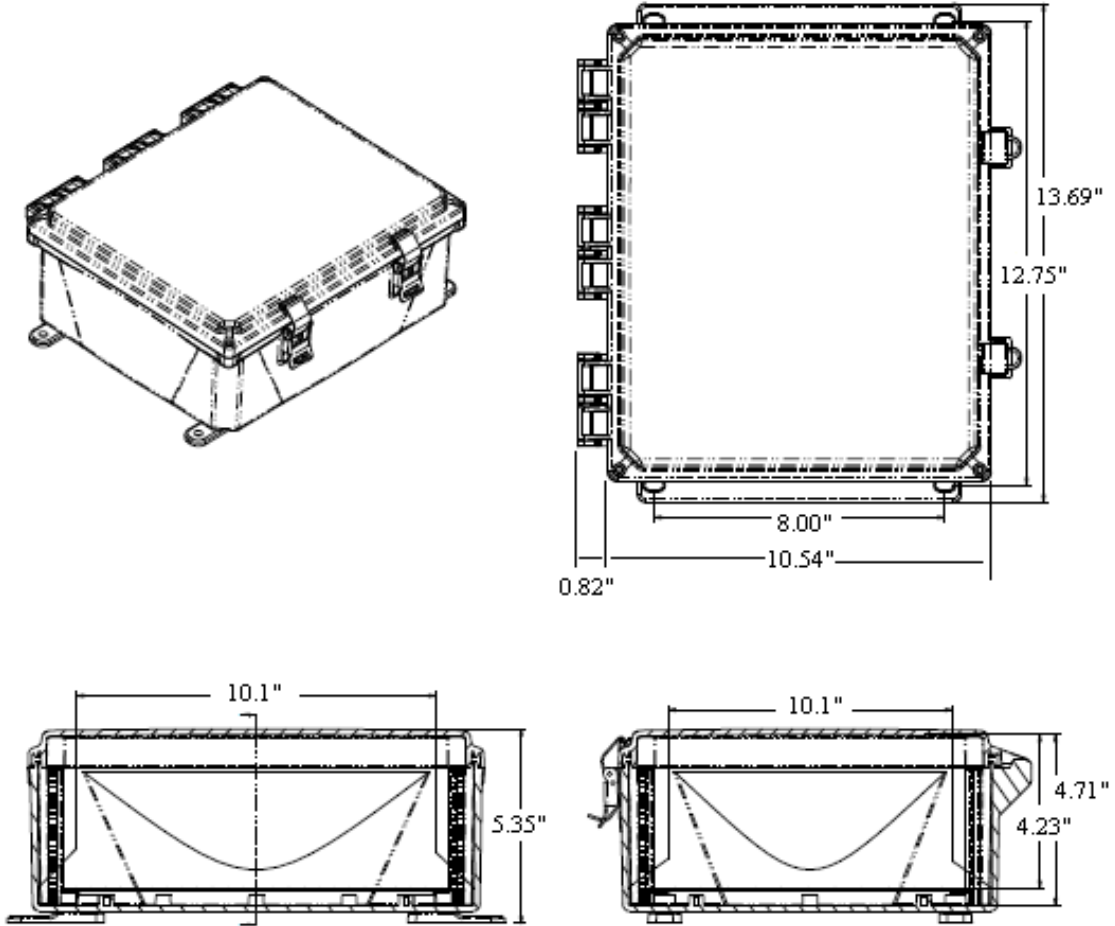

## §9.2 Clamp-on Transducer Installation Guide

### §9.2.1 Find the mounting site

- (A) Pipe must be full of liquids at the measurement site.
- (B) No heavy corrosion or deposition inside of the pipe.
- (C) Must be a safe location.
- (D) The straight run of the pipe must not be shorter than 15D as a general guideline, where D is the pipe diameter. Insufficient straight pipe length will degrade the accuracy of the results.
- (E) The transducer mounting site should be 10D straight run upstream and 5D straight run downstream (see the following drawing.)

(F) If there are flow disturbing parts such as pumps, valves, etc. on the upstream, the straight pipe length should be increased. The disturbance strength of those flow conducting parts will be (low to high):

*Single Bend -> Pipe Reduction / Enlargement -> Outflow Tee -> Same Plane Multiple Bends -> Inflow Tee -> Out of Plane Multiple Bends -> Valve -> Pump*

### §9.2.2 Transducer Configuration Method

There are three configurations can be used when installing the transducers, W-method, V-method and Z-method.

W-method is not commonly used. In some cases it can be used on small pipes, such as pipe size less than 32mm.

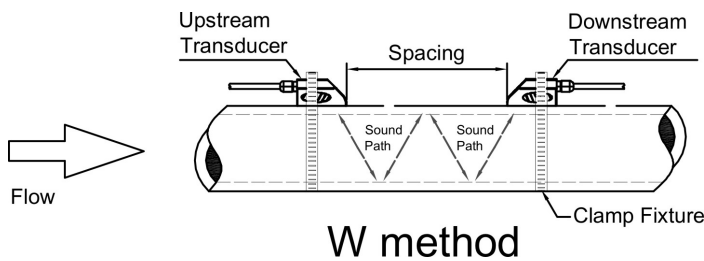
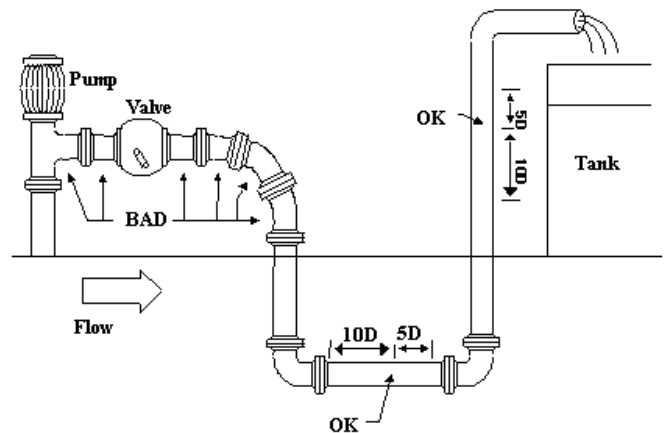

(a)

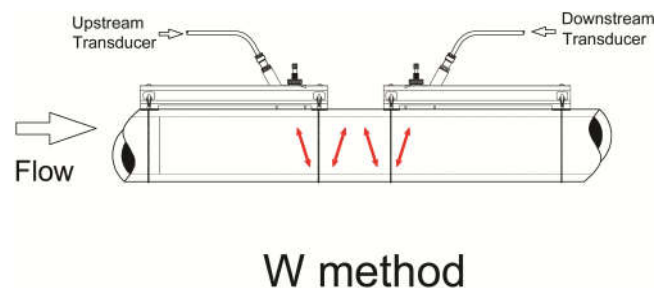

(b)

V-method is most commonly used configuration. It is applicable for pipes which size is between 25mm and 500mm. However, for old pipes and other difficult pipes, you may try Z-method if V-method does not work.

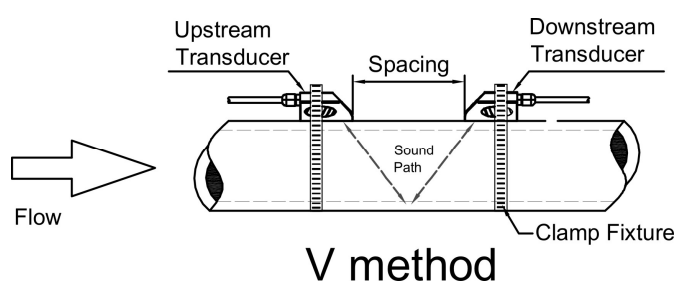

V method

(a)

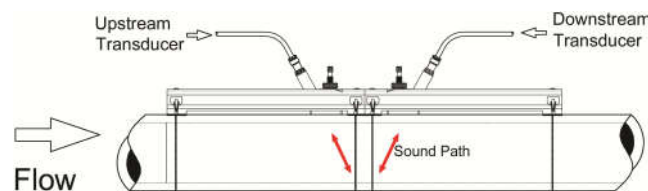

V method

(b)

Z-method is commonly used when the pipe diameter is between 300 millimeters and 5,000 millimeters.

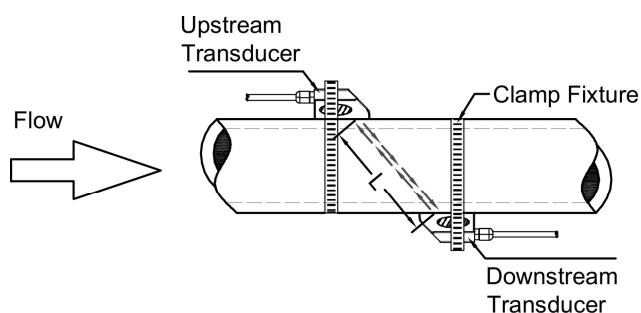

Z method

(a)

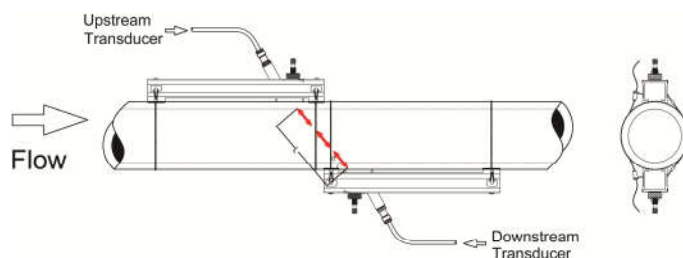

Z method

(b)

### §9.2.3 Configure the Main Unit

Enter the pipe, fluid and transducer information in menus M11-M24. The flowmeter will calculate the transducer installation spacing for you and display the result in M25. This spacing will be used later.

*Please note that, if your pipe material is PVC or other plastics, DO NOT select “5. PVC” in M14. Instead, select “9. Others”. Then, enter the shear-wave sound speed of that material in M15. Normally, this sound speed is around 1060m/s (3478ft/s).*

### §9.2.4 Prepare the Pipe Surface

Clean the pipe surface where the transducers will be mounted. Remove rust and paint. Sand the surface if not smooth. Use wet cloth to wipe off the powder after sanding. Dry up the surface. A

dry, clean surface will ensure a good acoustic bond between transducer and pipe.

### §9.2.5 Prepare the Transducer

Clean the transducer surface. Keep the surface dry.  
Put couplant on transducer surface as shown in the right figure.  
Do not put couplant more than necessary, especially for small pipe.



Note: Ultrasonic couplant can be grease, gel, and Vaseline, silicon or epoxy. Please read the instructions on those products carefully before using them. Spire Metering will not be responsible for any consequences caused by these products.

### §9.2.6 Install the Transducers

A)

**Notice:** For horizontal pipe line, it is recommended to install the transducers on the side instead of on the top or bottom of the pipe. This is to avoid air bubbles on the top and sediments on the bottom of the pipe.

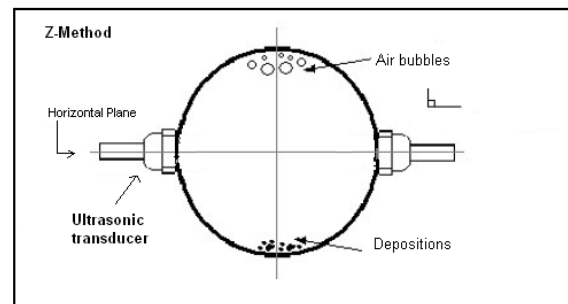

First, mark the transducer installation location on the pipe surface according to the mounting spacing given in menu M25. You may need to make a paper template to help you accurately and quickly locate the transducer positions as well as to center the transducers, especially if you plan to use Z-method for the installation.

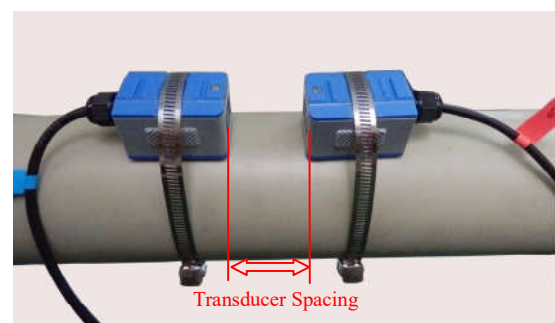

Then, connect the mounting fixture around the pipe. Leave the chain loose so you can slip the transducer underneath.

Apply a small amount of couplant in the prepared area of the pipe where transducers will be in contact.

Slip the transducer under the clamp fixture. Tighten the screw. Do the same thing for the other transducer. Use the figure on the right as a reference.

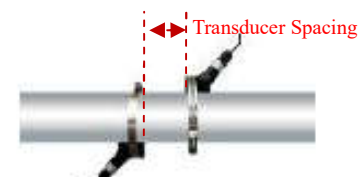

Z-method clamp-on installation for high-temperature transducers (S1HT/M1HT)

If the pipe material is metal, you may still need the clamp fixture to make sure the transducer surface is in tight contact with the pipe.

Finally, connect the transducer cables to the main unit.

**B)**



**Picture 1**



**Picture 2**

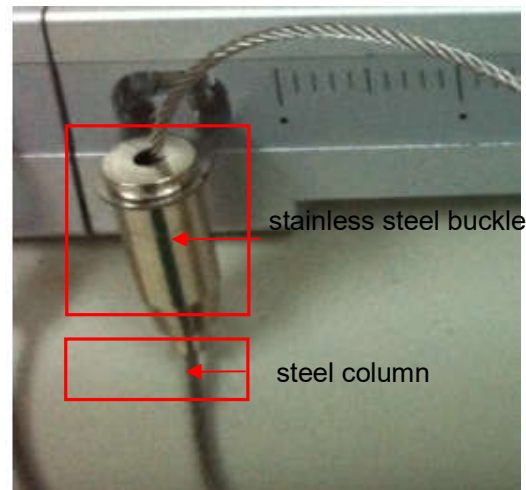

**Picture 3**

1. First, mark the transducer installation location on the pipe surface according to the mounting spacing given in menu M25.
2. Apply a small amount of couplant in the prepared area of the pipe where transducers will be in contact.
3. Put the transducers on the surface of the pipe.
4. Hang the steel wire strainer on the rack (Picture 2).  
On the other side, hang the stainless steel buckle (Picture 3).  
Tighten the steel wire, and one end of rack is fastened on the pipe.
5. On the other end of transducer, tighten it by same method.
6. Screw it down and make it attached the pipe. (Picture 1)
7. If want to take off transducers, loose the stainless steel buckle by pressing the steel column.

\* *Note that when flow velocity is very high, the range for R may extend.*

### ***§9.2.7 Fine Tune the Installation***

Check the readings of the triplet (signal strength S, signal quality Q and transit-time ratio R) in menu window M90 and then M91. Make sure they are at least in the operational ranges:

***Operational Ranges:***                       **$S \geq 60, \quad Q \geq 60, \quad 97\% \leq R \leq 103\%.$**

***Optimal Ranges:***                         **$S \geq 80, \quad Q \geq 80, \quad 99\% \leq R \leq 101\%.*$**

In ideal case where pipe condition and fluid condition are favorable for sound propagation, the triplet readings could be fine turned into the optimal ranges. If your triplet readings are not close to their optimal ranges, or, even not in their operational ranges, you need to adjust your transducer installation slightly and slowly, until you get the best readings.

If you are unable to get the triplet into their operational ranges, no matter how hard you try, then, you may need to check all the parameters you entered in menu windows M11 to M24. Make sure those values are correct. Whenever you make a change to those parameters, you need to check the transducer spacing reading in menu M25. If the spacing is changed, you need to reinstall the transducers accordingly.

If you still cannot get the right triplet readings, check the following:

- Is the pipe too old?
- Too much deposition inside of the pipe?
- Too much corrosion? Too much air bubble?
- Too thick liner? Empty or half-full pipe?
- Too close to pump / valve / elbow?

Please refer to section §2.11 for more suggestions. Please also check on our technical support website for more tips.

### **§9.3 Insertion Transducer Installation Guide**

A separate installation instruction should have been shipped with the product. If not, please contact the manufacturer at [support@spiremt.com](mailto:support@spiremt.com).



## **§9.4 Flow-cell Transducer Installation Guide**

A separate installation instruction should have been shipped with the product. If not, please contact the manufacturer at [support@spiremt.com](mailto:support@spiremt.com).

## **§9.5 Standard Pipe Dimensions**

Please refer to the following website for standard pipe dimensions:

[http://www.spiremt.com/support/support\\_pipesize.htm](http://www.spiremt.com/support/support_pipesize.htm)

## §9.6 Sound Speed Tables

**Table 9.6.1: Sound Speed in Water at atmosphere pressure. Unit: t (°C) v (m/s)**

t	v	t	v	t	v	t	v
0	1402.3	25	1496.6	50	1542.5	75	1555.1
1	1407.3	26	1499.2	51	1543.5	76	1555.0
2	1412.2	27	1501.8	52	1544.6	77	1554.9
3	1416.9	28	1504.3	53	1545.5	78	1554.8
4	1421.6	29	1506.7	54	1546.4	79	1554.6
5	1426.1	30	1509.0	55	1547.3	80	1554.4
6	1430.5	31	1511.3	56	1548.1	81	1554.2
7	1434.8	32	1513.5	57	1548.9	82	1553.9
8	1439.1	33	1515.7	58	1549.6	83	1553.6
9	1443.2	34	1517.7	59	1550.3	84	1553.2
10	1447.2	35	1519.7	60	1550.9	85	1552.8
11	1451.1	36	1521.7	61	1551.5	86	1552.4
12	1454.9	37	1523.5	62	1552.0	87	1552.0
13	1458.7	38	1525.3	63	1552.5	88	1551.5
14	1462.3	39	1527.1	64	1553.0	89	1551.0
15	1465.8	40	1528.8	65	1553.4	90	1550.4
16	1469.3	41	1530.4	66	1553.7	91	1549.8
17	1472.7	42	1532.0	67	1554.0	92	1549.2
18	1476.0	43	1533.5	68	1554.3	93	1548.5
19	1479.1	44	1534.9	69	1554.5	94	1547.5
20	1482.3	45	1536.3	70	1554.7	95	1547.1
21	1485.3	46	1537.7	71	1554.9	96	1546.3
22	1488.2	47	1538.9	72	1555.0	97	1545.6
23	1491.1	48	1540.2	73	1555.0	98	1544.7
24	1493.9	49	1541.3	74	1555.1	99	1543.9

**Table 9.6.2: Sound Speed and Viscosity Data of Liquids**

EF10 Wall-Mount Ultrasonic Flowmeter

Liquids	Sound Speed @ 25°C (77°F)		Kinematic Viscosity X 10 <sup>-6</sup>	
	m/s	ft/s	m <sup>2</sup> /s	ft <sup>2</sup> /s
Acetone	1,174	3,851.7	0.399	4.293
Acetaldehyde Alcohol	1,180	3,870		
Alcohol	1,207	3,960	1.396	15.02
Aviation kerosene	1,298	4,257		
Benzene	1,306	4,284.8	0.711	7.65
Carbine	1,121	3,677		
Ethanol	1,207	3,690	1.39	14.956
Ethyl benzene	1,586	4,389.8 (68°F)	0.797 (17°C)	8.575 (63°F)
Ethylene chloride	1,193	3,914	0.61	6.563
Ethylene trichloride	1,050	3,444		
Gasoline	1,250	4,100	0.8	0.1980
Gasoline 66#	1,171	3,841		
Gasoline 80#	1,139	3,736		
Glycol	1658	5,439.6		
50%Glycol / 50%H2O	1,578	5,177		
Glycerin	1,904	6,246.7	757.1	8,081.8
Ketone	1,310	4,297		
Kerosene	1,420	4,658	2.3	24.7
Oil (Castor)	1,477	4,854.8	0.670	7.209
Oil (Diesel)	1,250	4,101		
Oil (Peanut)	1,458	4,783.5		
Petroleum	1,290	4,231		
Tetrachlor-Methane	926	3,038.1	0.607	6.531
Toluene	1,328 (20°C)	4,357 (68°F)	0.644	6.929
Water, distilled	1,498	4,914.7	1.0	10.76

**Table 9.6.3: Sound Speed Data of Solids**

Material	Sound Speed Shear Wave ( 25°C )		Sound Speed Long. Wave ( 25°C )	
	m/s	ft/s	mm/us	in/us
Steel, 1% Carbon, hardened	3,150	10,335	5.88	0.2315
Carbon Steel	3,230	10,598	5.89	0.2319
Mild Steel	3,235	10,614	5.89	0.2319
Steel, 1% Carbon	3,220	10,565		
302 Stainless Steel	3,120	10,236	5.690	0.224
303 Stainless Steel	3,120	10,236	5.640	0.222
304 Stainless Steel	3,141	10,306	5.920	0.233
304L Stainless Steel	3,070	10,073	5.790	0.228
316 Stainless Steel	3,272	10,735	5.720	0.225
347 Stainless Steel	3,095	10,512	5.720	0.225
Aluminum	3,100	10,171	6.32	0.2488
Aluminum ( rolled )	3,040	9,974		
Copper	2,260	7,415	4.66	0.1835
Copper ( annealed )	2,235	7,628		
Copper ( rolled )	2,270	7,448		
CuNi ( 70%Cu 30%Ni )	2,540	8,334	5.03	0.1980
CuNi ( 90%Cu 10%Ni )	2,060	6,759	4.01	0.1579
Brass ( Naval )	2,120	6,923	4.43	0.1744
Gold ( hard-drawn )	1,200	3,937	3.24	0.1276
Inconel	3,020	9,909	5.82	0.2291
Iron ( electrolytic )	3,240	10,630	5.90	0.2323
Iron ( Armco )	3,240	10,630	5.90	0.2323
Ductile Iron	3,000	9,843		
Cast Iron	2,500	8,203	4.55	0.1791
Monel	2,720	8,924	5.35	0.2106

**Table 9.6.3 (continued): Sound Speeds in Solids**

Material	Sound Speed Shear Wave ( 25°C )		Sound Speed Long Wave ( 25°C )	
	m/s	ft/s	mm/us	in/us
Nickel	2,960	9,712	5.63	0.2217
Tin,rolled	1,670	5,479	3.32	0.1307
Titanium	3,125	10,253	6.10	0.2402
Tungsten,annealed	2,890	9,482	5.18	0.2039
Tungsten,drawn	2,640	8,661		
Tungsten,carbide	3,980	13,058		
Zinc,rolled	2,440	8,005	4.17	0.1642
Glass,Pyrex	3,280	10,761	5.61	0.2209
Glass,heavy silicate flint	2,380	7,808		
Glass,light borate crown	2,840	9,318	5.26	0.2071
Nylon	1,150	3,772	2.40	0.0945
Nylon,6-6	1,070	3,510		
Polyethylene ( LD )			2.31	0.0909
Polyethylene ( LD )	540	1,772	1.94	0.0764
PVC,CPVC	1,060	3,477	2.40	0.0945
Acrylic	1,430	4,690	2.73	0.1075
Asbestos Cement			2.20	0.0866
Tar Epoxy			2.00	0.0787
Mortar			2.50	0.0984
Rubber			1.90	0.00748